

Walker Rider Lawnmowers

ILLUSTRATED PARTS MANUAL

Model MT (20.0 HP / 25.0 HP & 26.0 HP EFI)
(Covers Serial Numbers 98-37480 and on)

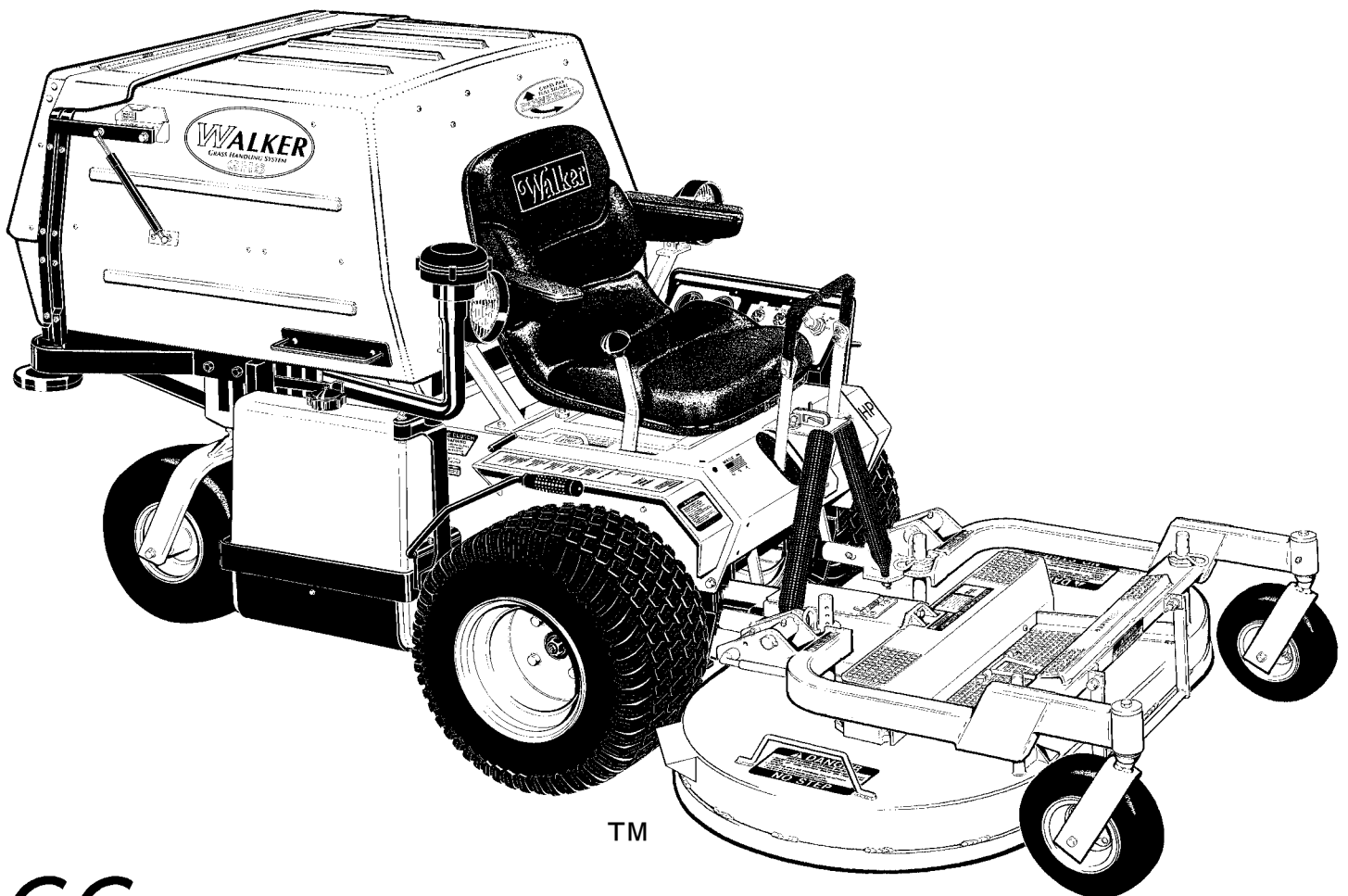

CE

Effective Date:

3/29/00

P/N 8000-4 Bound

P/N 8000-5 3-Ring

Price \$5.00

KEY TO ABBREVIATIONS USED IN THIS MANUAL

<i>Abbreviation</i>	<i>What it Represents</i>
AT.....	All-Terrain
CCW.....	Counter-clockwise
Conn.....	Connector
CW.....	Clockwise
DGHS.....	Deck, Grass Handling System (number refers to size in inches)
DML.....	Deck, Mulching (number refers to size in inches)
DSD.....	Deck, Side Discharge (number refers to size in inches)
EFI.....	Electronic Fuel Injection
ESNA (Fastener).....	Nylon Insert Locknut
FSC.....	Forward Speed Control
GA.....	Gauge
gal.....	gallon
GHS.....	Grass Handling System
GR (Fastener).....	Grade
HP.....	Horse Power
ID.....	Inside Diameter
" or in. (Dimension).....	inches
LH.....	Left Hand (orientated with operator on seat)
mm (Dimension).....	millimeters
MS (Fastener).....	Machine Screw
NPT.....	National Pipe Thread
NS (as part number).....	Item is not sold by Walker Manufacturing
OD.....	Outside Diameter
oz.....	ounce
PFHMS (Fastener).....	Phillips Flat Head Machine Screw
P/N.....	Part Number
PPHMS (Fastener).....	Phillips Pan Head Machine Screw
PPHSM (Fastener).....	Phillips Pan Head Sheet Metal (Screw)
PPHST (Fastener).....	Phillips Pan Head Self-Tapping (Screw)
PTHMS (Fastener).....	Phillips Truss Head Machine Screw
PTO.....	Power Take-Off
QKS.....	Quick Slide
qt.....	quart
RH.....	Right Hand (orientated with operator on seat)
SAE (Fastener).....	Society of Automotive Engineers
SBH (Fastener).....	Socket Button Head (Bolt)
SD.....	Side Discharge
SFH (Fastener).....	Slotted Flat Head
SHC (Fastener).....	Socket Head Cap
SHL (Fastener).....	Shoulder (Bolt)
S/N.....	Serial Number
Spg.....	Spring
SQH (Fastener).....	Square Head
SS (Fastener).....	Stainless Steel
Term.....	Terminal

ILLUSTRATED PARTS LIST

<i>Section of Mower Covered</i>	<i>Page</i>	<i>Section of Mower Covered</i>	<i>Page</i>
Decals			
Tractor Decals.....	2	Armrest Kit / Touch-Up Paint.....	46
Body / Chassis Assemblies		Comfort Seat / Armrest Kit	48
Body / Chassis Assembly (GHS Models).....	4	Suspension Seat Kit.....	50
Rear Body Assembly (GHS Models).....	6	Light Kit	52
Body Assembly (SD Models)	8	Cold Start Kit / Speed Up Kit.....	54
Tractor Components		Power Dump Kit (7.0 Bushel GHS Models Only) ...	56
Main Component Power Transmission		Power Dump Kit (9.5 Bushel GHS Models Only) ...	58
(GHS Models).....	10	No Catch Deflector Kit (7.0 / 9.5 Bushel)	60
(SD Models).....	12	Tail Weight Kit	62
Engine Group.....	14	Tail Wheel Lock Kit.....	64
Hydrostatic Ground Drive Assemblies	16	Wide Tail Wheel / All-Terrain Tire Kit & Tire Chain Sets	66
Steering Control Assemblies.....	18	Maintenance	
Throttle & Choke Control Assembly.....	20	Lubrication Points.....	68
Parking Brake Assembly	22	EFI Wiring Schematic	70
GHS Group	24	Wiring Schematic	72
GHS Powerfil® Assembly.....	26	Warranty	
GHS 7.0 Bushel Catcher & Exhaust		Limited Warranty	73
Deflector Assemblies	28		
GHS 9.5 Bushel Catcher Assembly	30		
Instrument Panel Assembly	32		
Electrical Assembly.....	34		
Electrical Connectors.....	36		
Options and Kits			
EFI Body & Electrical Assembly.....	38		
EFI Engine Fuel & Muffler Assembly	40		
EFI Instrument Panel Assembly.....	42		
Power Deck Lift Kit.....	44		

TRACTOR DECALS

ITEM NO.	PART NO.	DESCRIPTION	LOCATION	NO. REQ'D GHS	NO. REQ'D SD
Walker Product and Operation Decals					
1	7802	RH Fender	Body, RH Side Near Seat	1	1
2	5856	Made in USA	Body	1	1
3	5803	Walker Manufacturing Logo	Body	1	1
4	5813-1	Powerfil®	7.0 / 9.5 Bushel Catcher, Front	1	0
5	5801	GHS	7.0 / 9.5 Bushel Catcher (one on each side)	2	0
6	5800	Walker Mower (4 x 7-1/2)	Utility Bed (one on each side)	0	2
7	5806	Blade Clutch	Body, RH Side	1	1
Danger Decals Warning Decals Caution Decals					
8	5804	Danger, Rotating Blower Blades	Body Near Body Chute	1	0
9	7818	Warning, Read Manual	Body	1	1
10	6810	Danger, Engine Exhaust	Engine	1	1
11	5868	Danger, Pinch Point	7.0 / 9.5 Bushel Catcher Mounting Frame Assembly (one on each side)	2	0
Maintenance Decals					
12	7809	Parking Brake	Body, RH Side below Seat	1	1
13	7820	Body Release Decal	Body, RH Side	1	1
14	7819	Throttle	Body, LH Side	1	1
15	8819	Choke	Body, LH Side	1	1
16	5855	Important, Engine Cooling	Engine	1	1
17	5810-2	Reservoir	Hydrostatic Drives (one on each)	2	2
18	5810-1	Axle Oil Level	Gear Axle Drive Assemblies (one on each)	2	2
19	5819	Blower Maintenance	Blower Housing	1	0
20	6875	PTO Alignment Arrow	Universal Joint Tube Assembly	1	1
21	7827	Oil Level	Jackshaft Support	1	1
22	5874	Push to Release	7.0 / 9.5 Bushel Catcher Safety Latch	1	0
23	8825	Front Body Closure	Rear Cross Member, Body	1	1
24	8821	20 HP	Body	1*	1*
	8822	25 HP	Body	1*	1*
	8822-10	26 HP	Body	1*	1*
25	5869	Removable Screen	7.0 / 9.5 Bushel Catcher Removable Screen	1	0
Option Decals**					
26	7633	Power Dump Switch	Body	1	0
27	8555	Tail Lock Switch	FSC Lever Assembly - Switch Mount Bracket	1	1
28	8654	Power Deck Lift Switch	Body, RH Side	1	1
29	8500-8	No Catch Deflector	7.0 / 9.5 Bushel No Catch Deflector, LH Side (refer to No Catch Deflector Kit Listing)	1	0

* 20 HP Decal is Standard. 25 HP Decal furnished only with 25 HP Engine Upgrade Option.
26 HP Decal furnished only with Optional 26 HP EFI Engine.

** Option Decals applied only to units with corresponding Options installed.

NOTE: All parts requiring decals are shipped with decals applied.

Use only genuine **Walker®** replacement parts.

Effective Date 3/29/00

TRACTOR DECALS

SD Model

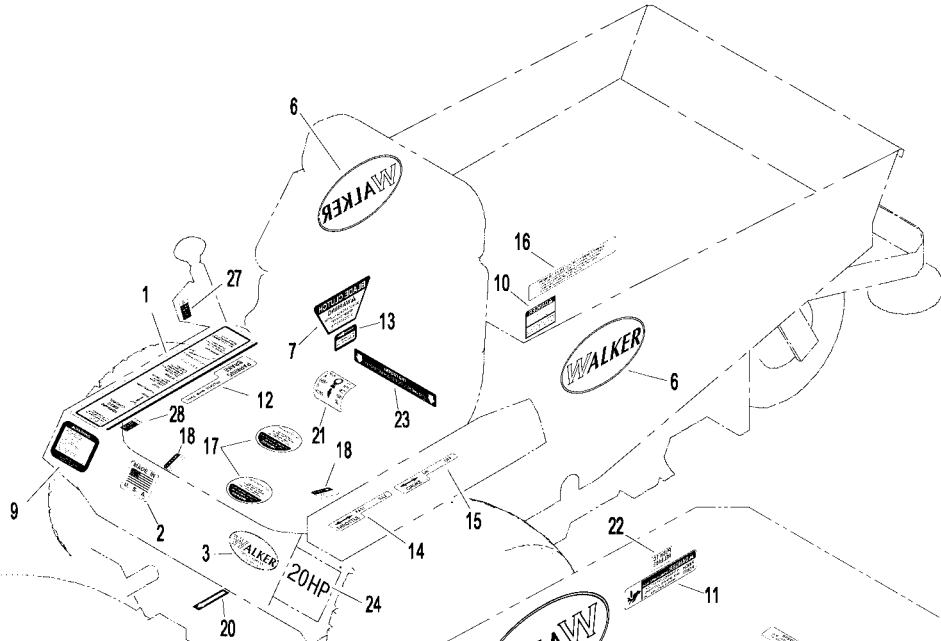

*Refer to Decks
Parts Manual
for Deck Decals*

GHS Model

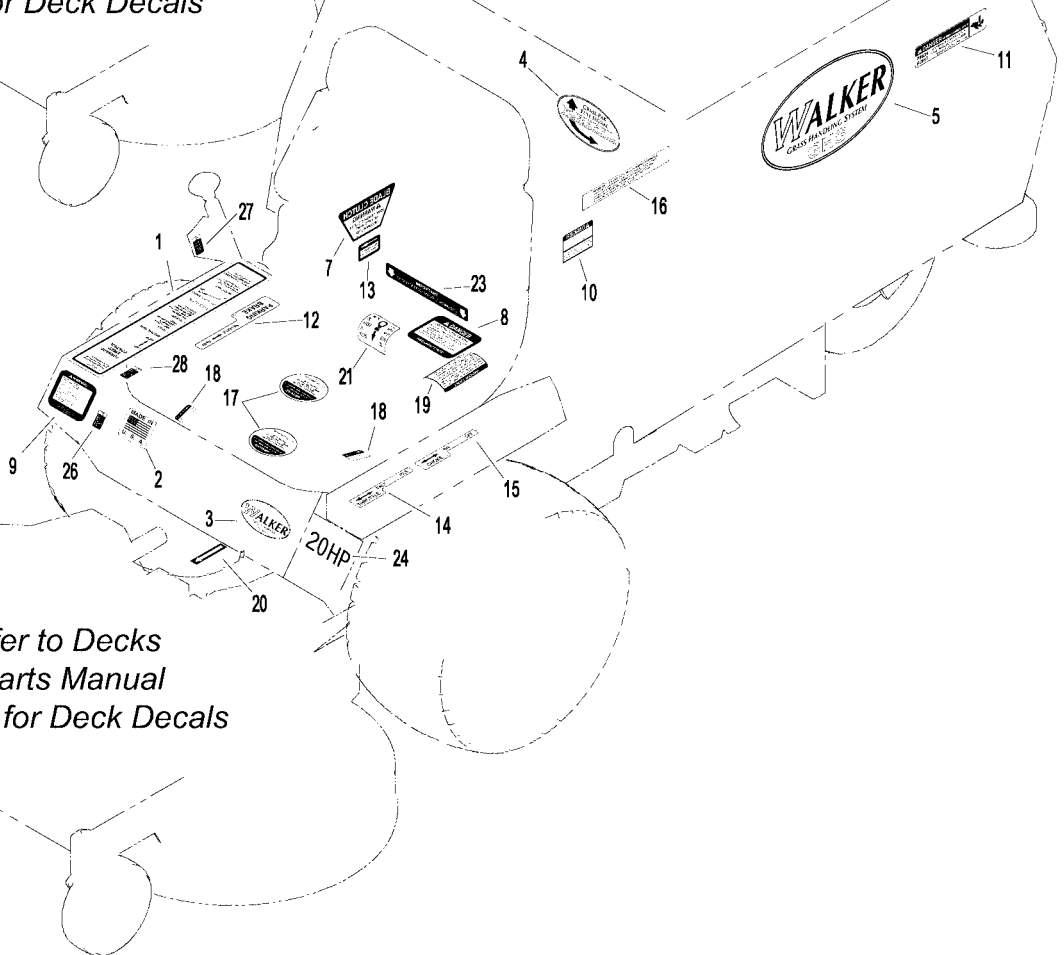

*Refer to Decks
Parts Manual
for Deck Decals*

BODY / CHASSIS ASSEMBLY (GHS MODELS)

ITEM NO.	PART NO.	DESCRIPTION	LOCATION	NO. REQ'D GHS	NO. REQ'D SD		
Seat Assembly							
			43	8038-1	Spacer, Tail Wheel Axle	2	
1	5103	Seat	1	44	8037	Bearing Cone (3/4 ID)	4
2	7203	Seat Spring Plate	1	45	8035	Tail Wheel & Tire Assembly (13 x 5.00-6) (With Bearing Race)	2
3	7223	Compression Spring (1/2 x 1)	2				**
4	7845	Rubber Bumper (1.375 OD x .63)	2	7035-1	Tire Only (13 x 5.00-6)		**
5	7846	Rubber Washer (3/8 ID x 1-1/4 OD x 1/8)	2	8036	Wheel & Hub Only (6 x 3.25) (Includes Item # 41 & Bearing Race)		**
6	7204	Shoulder Bolt, Seat Mount	2				**
7	7440-5	Shock Mount (1.25 D x .75)	2	8037-2	Bearing Race		**
Rear Bumper Assembly (GHS Models Only)*							
			46	8038	Tail Wheel Axle (3/4 x 10-3/8)	1	
8	7516	7.0 / 9.5 Rear Bumper	1	47	7070	Wheel & Tire Assembly (18 x 9.5-8)	2
9	7516-5	Catcher Pivot Bushing	2		7070-1	Tire Only (18 x 9.5-8)	**
10	5162	Roller Wheel (5")	2		5070-4	Wheel Only (8 x 7)	**
11	7517-2	Catcher Pivot Plate	2	48	8300	Chassis Frame	1
Body Assembly							
				F002	10-24 Keps Nut	12	
12	NS	Body ID Plate	1	F004	1/4-20 Keps Nut	7	
13	5845	Bumper, Tapered (1.50 OD x 1.25)	4	F005	1/4-20 ESNA Nut	1	
14	8118	Heat Deflector	1	F009	5/16-18 Whiz Locknut	13	
15	7422	Panel Guard	1	F012	3/8-16 Keps Nut	8	
16	5989-4	Dome Plug (3/8)	4	F013	3/8-16 Whiz Locknut	2	
17	5989-3	Dome Plug (5/16)	2	F014	3/8-16 ESNA Nut	4	
18	7146	13mm Ball Stud	2	F020	5/16-18 ESNA Nut	1	
19	7844	Rubber Bumper (1.25 OD x .25)	1	F025	10-24 x 3/8 PPHMS	4	
20	7147	Spring Clip	2	F029	1/4-20 x 1/2 Hex Bolt	2	
21	7145	Gas Spring Assembly (Includes Items # 19 & 21)	1	F031	1/4-20 x 5/8 Hex Bolt	1	
				F034	5/16-18 x 3/4 Hex Bolt	2	
22	7222	Spring, Body Release	1	F038	3/8-16 x 1 Hex Bolt	6	
23	7383-1	Body Latch Hook	1	F040	3/8-16 x 1-1/2 Hex Bolt	2	
24	7854	Plastic Tip, Red	1	F042	3/8-16 x 2-1/4 Hex Bolt	2	
25	5989-9	Dome Plug (1/4)	10	F049	5/16 SAE Washer	1	
26	8100	Welded Body	1	F050	1/4 SAE Washer	1	
27	5180	Edge Molding, Lever Opening	2	F051	3/8 SAE Washer	2	
28	5989-5	Dome Plug (7/16)	2	F059	3/8 Wave Spring Washer	2	
Tilt-Up Latch Assembly							
				F093	5/16-18 x 1 Hex Bolt	1	
29	5847	Plastic Tip	1	F113	5/16-18 x 5/16 Set Screw	2	
30	5744-20	Tilt-Up Latch Spring Arm	1	F128	10-24 x 3/8 PTHMS	4	
31	5744-10	Spring Pivot Bushing	1	F151	3/8-16 x 7/8 Hex Bolt	2	
32	5744-15	Compression Spring (3/8 x 5/8)	1	F157	1/2-20 x 1-1/4 Wheel Lug Bolt	8	
33	5744-13	Mount Angle, LH	1	F205	5/16-18 x 1/4 Set Screw, Knurl Point	2	
34	5744-12	Hook, Tilt-Up Latch	1	F206	#2 x 3/16 Drive Pin	2	
35	5744-14	Mount Angle, RH	1	F218	7/16 Split Lock Washer	2	
Chassis Assembly							
				F219	7/16-14 x 1-1/4 Hex Bolt	2	
36	5267-1	Retainer Collar (1") (Includes Item # F113)	1	F227	3/8 x 1-1/4 x 1/8 Plastic Washer	2	
				F241	.375 x .875 x .10 Washer	4	
37	5270-1	Pivot Bearing	2	F341	Coil Roll Pin (7/64 x 9/16)	1	
38	5842-1	Spacer Washer, Tail Wheel Fork	1	F342	5/16 Conical Washer	2	
39	7420	Tail Wheel Fork	1				
40	5830-3	Grease Fitting (45 Degree)	2				
41	8039	Nut, Tail Wheel Axle	2				
42	8037-1	Seal, Tail Wheel Axle	4				

* Rear Bumper Assembly for SD Models is not shown here. Refer to **BODY ASSEMBLY (SD MODELS)**, Page 8.

** Service Part Only

BODY / CHASSIS ASSEMBLY (GHS MODELS)

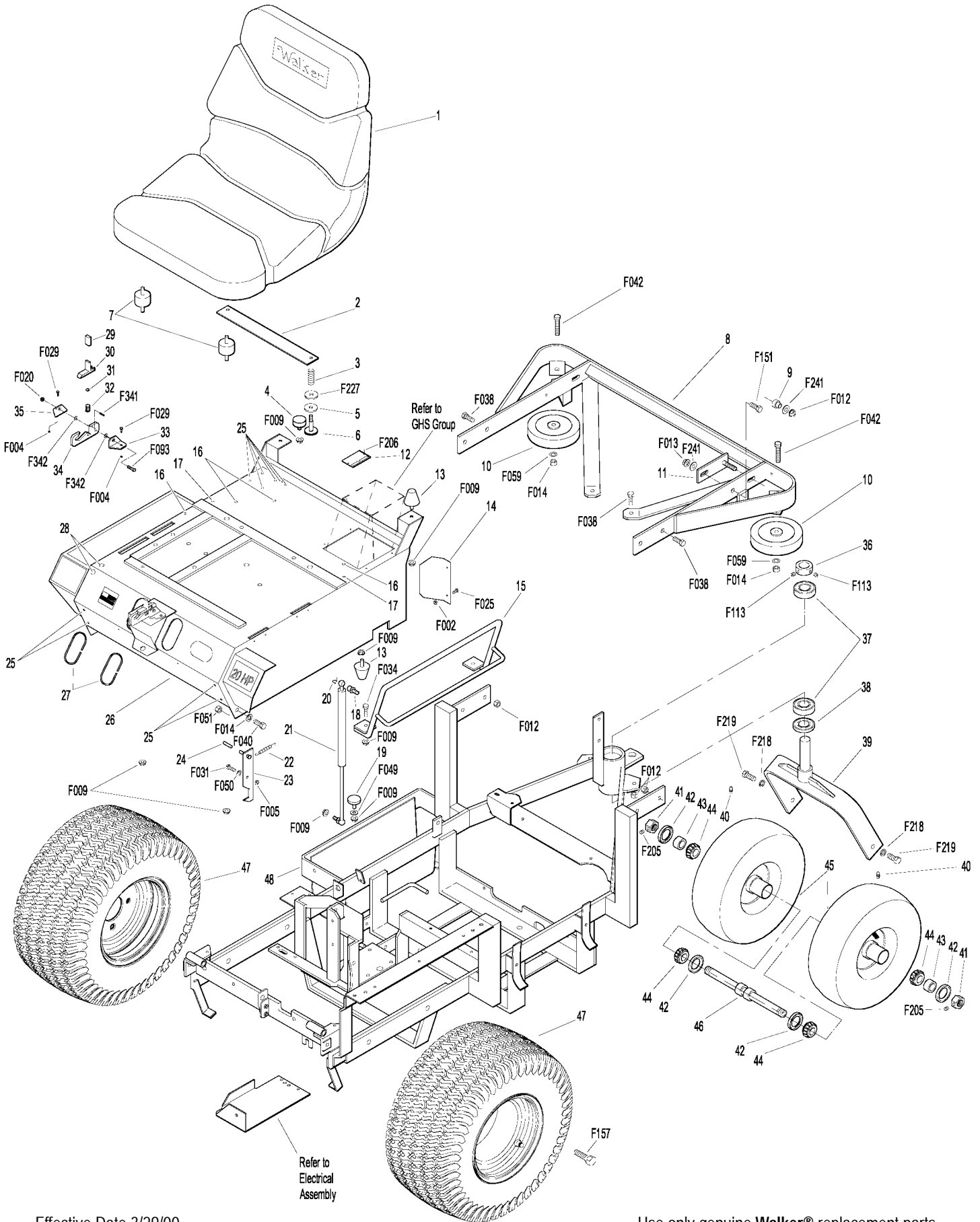

Effective Date 3/29/00

Use only genuine Walker® replacement parts.

REAR BODY ASSEMBLY (GHS MODELS)

ITEM NO.	PART NO.	DESCRIPTION	NO. REQ'D	ITEM NO.	PART NO.	DESCRIPTION	NO. REQ'D
Rear Body Assembly (GHS Models)				Fasteners			
1	7190-3	Insulation Foam Pad (5 x 20)	1	F002		10-24 Keps Nut	13
2	8082	Heat Shield	1	F004		1/4-20 Keps Nut	5
3	8515-3	Catcher Support Frame	1	F009		5/16-18 Whiz Locknut	2
4	7190-2	Insulation Foam Pad, RH	1	F025		10-24 x 3/8 PPHMS	8
5	7190-1	Insulation Foam Pad, LH	1	F026		10-24 x 1/2 PPHMS	4
6	7145	Gas Spring Assembly (Includes Items # 8 & 9)	1	F027		10-24 x 5/8 PPHMS	1
7	8389-2	Splash Guard	1	F031		1/4-20 x 5/8 Hex Bolt	2
8	7147	Spring Clip	2	F032		1/4-20 x 3/4 Hex Bolt	3
9	7146	13mm Ball Stud	2	F085		3/16 Rivet Backup Washer	1
10	8105-1	Rear Body Panel	1	F178		1/4 x 1 Fender Washer	3
11	8309-12	Pad, Rubber	1				

NOTE: Rear Bumper Assembly for GHS Models is not shown here. Refer to **BODY / CHASSIS ASSEMBLY (GHS MODELS)**, Page 4.

REAR BODY ASSEMBLY (GHS MODELS)

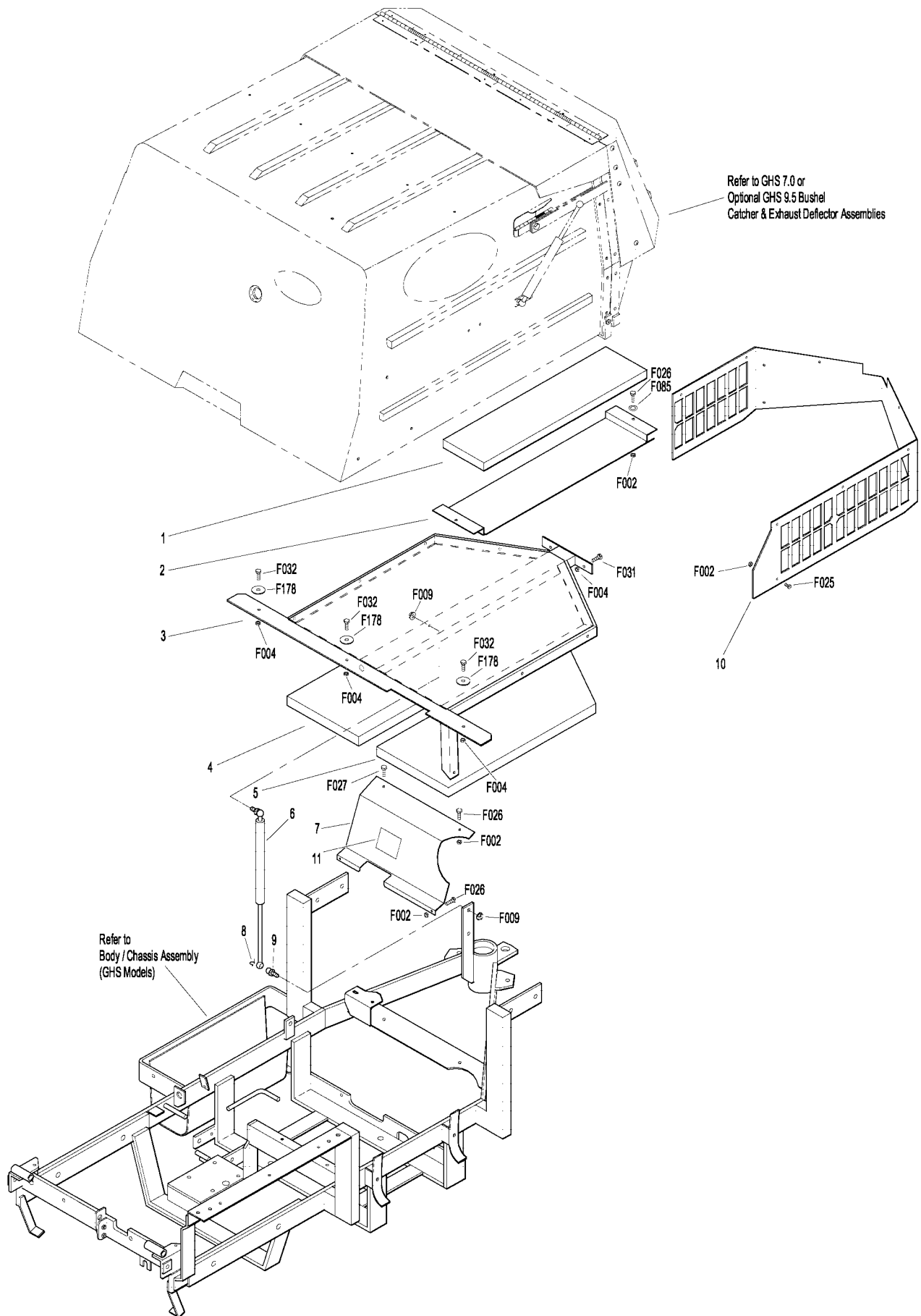

BODY ASSEMBLY (SD MODELS)

ITEM NO.	PART NO.	DESCRIPTION	NO. REQ'D	ITEM NO.	PART NO.	DESCRIPTION	NO. REQ'D
Utility Bed Assembly				Fasteners			
1	8650-2	Utility Bed	1	F002		10-24 Keps Nut	16
2	7190-2	Insulation Foam Pad, RH	1	F009		5/16-18 Whiz Locknut	2
3	7190-1	Insulation Foam Pad, LH	1	F012		3/8-16 Keps Nut	6
Rear Bumper Assembly (SD Models)				F013		3/8-16 Whiz Locknut	4
4	7153-3	Cover Plate	1	F014		3/8-16 ESNA Nut	2
5	7145	Gas Spring Assembly (Includes Items # 6 & 7)	1	F025		10-24 x 3/8 PPHMS	8
6	7147	Spring Clip	2	F026		10-24 x 1/2 PPHMS	3
7	7146	13mm Ball Stud	2	F027		10-24 x 5/8 PPHMS	1
8	7521	Rear Bumper	1	F038		3/8-16 x 1 Hex Bolt	6
9	5162	Roller Wheel (5")	2	F040		3/8-16 x 1-1/2 Hex Bolt	2
10	8105-1	Rear Body Panel	1	F042		3/8-16 x 2-1/4 Hex Bolt	2
11	8389-2	Splash Guard	1	F051		3/8 SAE Washer	4
12	8309-12	Pad, Rubber	1	F059		3/8 Wave Spring Washer	2
				F128		10-24 x 3/8 PTHMS	8

NOTE: Refer to **BODY / CHASSIS ASSEMBLY (GHS MODELS)**,
Page 4 for all common parts used on both models.

MAIN COMPONENT POWER TRANSMISSION (GHS MODELS)

ITEM NO.	PART NO.	DESCRIPTION	NO. REQ'D	ITEM NO.	PART NO.	DESCRIPTION	NO. REQ'D
Clutch Lever Assembly				40	7349-3	Idler Arm	1
1	8358	Clutch Lever (Includes Items # 2 & 3)	1	41	7201-4	Inner Race (1-1/2)	2
2	5830	Grease Fitting	7	42	5221	Extension Spring (3/4 x 4)	2
3	7860	Handle Grip	1	43	5268	Bearing (3/4)	2
4	7303-10	Clutch Actuator Bolt (3/8)	1	44	7241-21	Transmission Drive Pulley, Micro-V (Includes Item # F171)	1
5	7380-5	Knuckle Joint	1	45	8349	Transmission Belt Tightener Arm	1
6	7226-10	Compression Spring (3/4 x 2-1/2), 3/8 ID	1	46	8393-2	Jackshaft Support	1
7	5841	Retainer Washer	4	47	8273	Jackshaft (3/4 x 7-1/2)	1
8	8130-5	Push Rod, Clutch Actuator (Threaded Tube)	1	48	7240-20	Jackshaft Drive Pulley (Includes Item # F171)	1
9	8130-10	Clutch Actuator Rod Assembly (Includes Items # 2, 4-6, 8, F054, F336 & F353)	1	Fasteners			
10	7201-3	DU Bearing	6	F003	1/4-28 Hex Nut		2
11	7201-5	Inner Race (2-1/4)	1	F004	1/4-20 Keps Nut		3
12	8368	PTO Belt Tightener	1	F005	1/4-20 ESNA Nut		1
13	8243	Clutch Idler Pulley Assembly (Includes Items # 13, 14, 15 & F070)	1	F009	5/16-18 Whiz Locknut		3
	8243-1	Clutch Idler Pulley	1	F012	3/8-16 Keps Nut		8
14	5265	Bearing (3/4)	1	F029	1/4-20 x 1/2 Hex Bolt		1
15	8243-3	Hub, Idler Pulley	1	F035	5/16-18 x 1-1/4 Hex Bolt		2
16	8375	PTO Belt Tightener Stop	1	F040	3/8-16 x 1-1/2 Hex Bolt		1
17	7377	Plastic Washer (1 x .438 x .025)	2	F041	3/8-16 x 1-3/4 Hex Bolt		2
18	7378	Pivot Bearing (7/16 x 9/16)	1	F042	3/8-16 x 2-1/4 Hex Bolt		3
19	5281-5	Clevis Pin (1/4 x 0.80)	2	F043	3/8-16 x 3 Hex Bolt		1
20	5280	Clevis (1/4)	2	F047	3/8-16 x 4-1/2 Hex Bolt		1
21	8305	Brake Actuator Rod	1	F054	AN960616 Washer		3
22	8370	Bearing, Brake Actuator	1	F061	1/4 Internal Star Lock Washer		1
23	8250	Brake Spring (1/2 x 2-1/2)	1	F067	3/16 x 3/16 x 1 Key		2
24	8369	Brake Actuator (Includes Items # 2 & 22)	1	F069	3/32 x 1/2 Cotter Pin		2
PTO Drive Shaft Assembly				F070	1-3/4 Internal Snap Ring		1
25	7050-1	Dipstick, Gearbox	1	F075	5/16-18 x 1/2 SQH Set Screw		2
26	8371	Mount Bracket, Brake Band	1	F114	5/16-18 x 5/8 SQH Set Screw		2
27	8377	Brake Band Guide	1	F116	1/4-20 x 1-1/4 Hex Bolt		1
28	8050	PTO Gearbox	1	F121	5/16-18 x 3/8 x 1 SHL Bolt		1
29	5245	Idler Pulley (3")	2	F131	5/16-18 x 1/2 Hex Bolt		2
30	7248	Ground Drive Belt, Micro-V	1	F132	1/4-20 x 2-3/4 Hex Bolt		1
31	7275-15	Universal Joint Tube Assembly	1	F135	3/16 x 3/16 x 1-3/4 Key		1
32	7523-2	Clevis Pin (1/4 x 5/8)	1	F163	5/16-18 x 3/4 SQH Set Screw		2
33	8304	Brake Band (14-1/2)	1	F168	5/16 Split Lock Washer		6
34	6231	Drive Belt (3VX355)	1	F171	5/16-18 x 3/8 Set Screw		4
35	7236	PTO Drive Pulley (Includes Items # F075 & F114)	1	F178	1/4 x 1 Fender Washer		1
36	8237	Engine Pulley (Includes Item # F163)	1	F182	5/8 x 1/4 x 1/8 Washer		2
37	8230	Engine PTO Belt	1	F186	5/64 x 1/2 Cotter Pin		1
Jackshaft Assembly				F226	5/16-18 x 7/8 Hex Bolt		6
38	7245-1	Idler Pulley (3/8 Groove)	1	F240	1/4 x 1/4 x 2-1/4 Key		1
39	6325-2	Spacer Bushing (5/16)	2	F241	.375 x .875 x .10 Washer		1
				F325	1/4-20 x 3 Hex Bolt		1
				F336	3/8-16 Jam Nut		1
				F353	3/8-16 ESNA LP Nut		1

Use only genuine **Walker®** replacement parts.

Effective Date 3/29/00

MAIN COMPONENT POWER TRANSMISSION (SD MODELS)

ITEM NO.	PART NO.	DESCRIPTION	NO. REQ'D	ITEM NO.	PART NO.	DESCRIPTION	NO. REQ'D
Clutch Lever Assembly				40	7349-3	Idler Arm	1
1	8358	Clutch Lever (Includes Items # 2 & 3)	1	41	7210-4	Inner Race (1-1/2)	2
2	5830	Grease Fitting	7	42	5221	Extension Spring (3/4 x 4)	2
3	7860	Handle Grip	1	43	5268	Bearing (3/4)	2
4	7303-10	Clutch Actuator Bolt (3/8)	1	44	7241-2	Transmission Drive Pulley, Micro-V (Includes Item # F171)	1
5	7380-5	Knuckle Joint	1	45	8349	Transmission Belt Tightener Arm	1
6	7226-10	Compression Spring (3/4 x 2-1/2), 3/8 ID	1	46	8393	Jackshaft Support	1
7	5841	Retainer Washer	4	47	8273	Jackshaft (3/4 x 7-1/2)	1
8	8130-5	Push Rod, Clutch Actuator (Threaded Tube)	1	48	7240-1	Jackshaft Drive Pulley (Includes Item # F171)	1
9	8130-10	Clutch Actuator Rod Assembly (Includes Items # 2, 4-6, 8, F054, F336 & F353)	1	Fasteners			
10	7201-3	DU Bearing	6	F003	1/4-28 Hex Nut		2
11	7201-5	Inner Race (2-1/4)	1	F004	1/4-20 Keps Nut		3
12	8368	PTO Belt Tightener	1	F005	1/4-20 ESNA Nut		1
13	8243	Clutch Idler Pulley Assembly (Includes Items # 13, 14, 15 & F070)	1	F009	5/16-18 Whiz Locknut		3
	8243-1	Clutch Idler Pulley	1	F012	3/8-16 Keps Nut		8
14	5265	Bearing (3/4)	1	F029	1/4-20 x 1/2 Hex Bolt		1
15	8243-3	Hub, Idler Pulley	1	F035	5/16-18 x 1-1/4 Hex Bolt		2
16	8375	PTO Belt Tightener Stop	1	F040	3/8-16 x 1-1/2 Hex Bolt		1
17	7377	Plastic Washer (1 x .438 x .025)	2	F041	3/8-16 x 1-3/4 Hex Bolt		2
18	7378	Pivot Bearing (7/16 x 9/16)	1	F042	3/8-16 x 2-1/4 Hex Bolt		3
19	5281-5	Clevis Pin (1/4 x 0.80)	2	F043	3/8-16 x 3 Hex Bolt		1
20	5280	Clevis (1/4)	2	F047	3/8-16 x 4-1/2 Hex Bolt		1
21	8305	Brake Actuator Rod	1	F054	AN960616 Washer		3
22	8370	Bearing, Brake Actuator	1	F061	1/4 Internal Star Lock Washer		1
23	8250	Brake Spring (1/2 x 2-1/2)	1	F067	3/16 x 3/16 x 1 Key		2
24	8369	Brake Actuator (Includes Items # 2 & 22)	1	F069	3/32 x 1/2 Cotter Pin		2
25	7050-1	Dipstick, Gearbox	1	F070	1-3/4 Internal Snap Ring		1
PTO Drive Shaft Assembly				F075	5/16-18 x 1/2 SQH Set Screw		1
26	8371	Mount Bracket, Brake Band	1	F114	5/16-18 x 5/8 SQH Set Screw		1
27	8377	Brake Band Guide	1	F116	1/4-20 x 1-1/4 Hex Bolt		1
28	8050	PTO Gearbox	1	F121	5/16-18 x 3/8 x 1 SHL Bolt		1
29	5245	Idler Pulley (3")	2	F131	5/16-18 x 1/2 Hex Bolt		2
30	7248	Ground Drive Belt, Micro-V	1	F132	1/4-20 x 2-3/4 Hex Bolt		1
31	7275-15	Universal Joint Tube Assembly	1	F135	3/16 x 3/16 x 1-3/4 Key		1
32	7523-2	Clevis Pin (1/4 x 5/8)	1	F163	5/16-18 x 3/4 SQH Set Screw		2
33	8304	Brake Band (14-1/2)	1	F168	5/16 Split Lock Washer		6
34	6231	Drive Belt (3VX355)	1	F171	5/16-18 x 3/8 Set Screw		4
35	7236	PTO Drive Pulley (Includes Items # F075 & F114)	1	F178	1/4 x 1 Fender Washer		1
36	8237	Engine Pulley (Includes Item # F163)	1	F182	5/8 x 1/4 x 1/8 Washer		2
37	8230	Engine PTO Belt	1	F186	5/64 x 1/2 Cotter Pin		1
Jackshaft Assembly				F226	5/16-18 x 7/8 Hex Bolt		6
38	7245-1	Idler Pulley (3/8 Groove)	1	F240	1/4 x 1/4 x 2-1/4 Key		1
39	6325-2	Spacer Bushing (5/16)	2	F241	.375 x .875 x .10 Washer		1
				F325	1/4-20 x 3 Hex Bolt		1
				F336	3/8-16 Jam Nut		1
				F353	3/8-16 ESNA LP Nut		1

Use only genuine **Walker®** replacement parts.

Effective Date 3/29/00

MAIN COMPONENT POWER TRANSMISSION (SD MODELS)

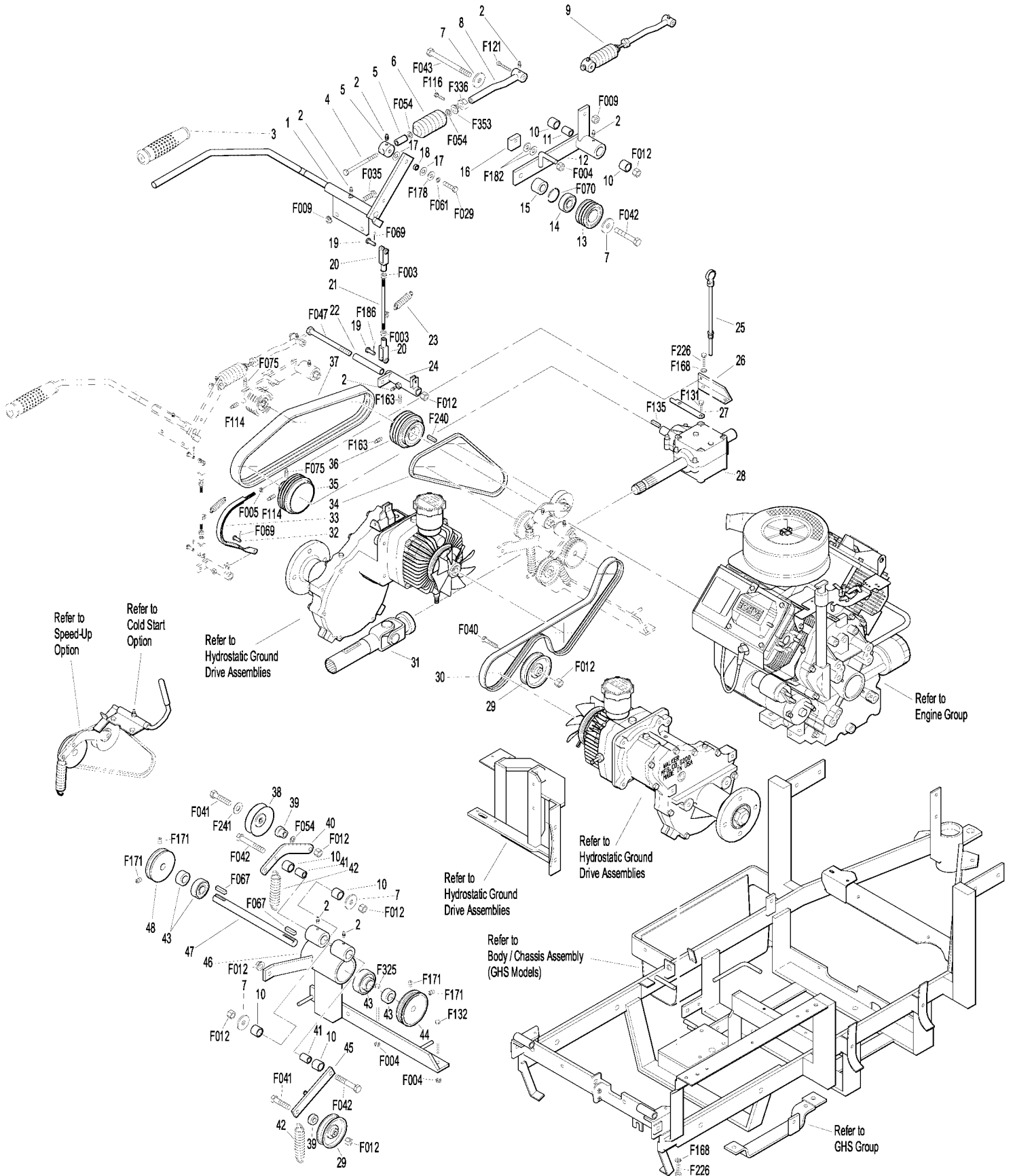

ENGINE GROUP

ITEM NO.	PART NO.	DESCRIPTION	NO. REQ'D	ITEM NO.	PART NO.	DESCRIPTION	NO. REQ'D
Precleaner Assembly				Exhaust Assembly			
1	7026-2	Remote Precleaner (Includes Item # 5)	1	40	8021	Engine Brace	1
2	7440	Shock Mount (1.0 OD x .75)	3	41	NS	Gasket (Kohler 240410)	2
3	7028-20	Rear Precleaner Mount	1	42	NS	Nut (Kohler M-0841080)	4
4	7027	Elbow, Precleaner	1	43	8530	Muffler Grass Shield	1
5	7840	Hose Clamp (1-5/6 to 2-1/4)	5	44	8897	Muffler Band Clamp	2
6	5088-10	Air Cleaner	1	45	8013-5	Muffler Heat Shield	1
7	5090-3	Safety Filter	1	46	8013-1	Muffler	1
8	5090-10	Air Cleaner Cartridge	1	47	8013-4	Exhaust Pipe, Rear	1
9	5088-1	Air Cleaner Band	1	48	8013-6	Exhaust Pipe, Front	1
10	5090-2	Vacuator Valve	1				
11	5091-10	Air Flow Indicator & Nipple	1	Fasteners			
12	8026	Air Hose, Cleaner (MT)	1	F009	5/16-18 Whiz Locknut		13
13	7031	Tube Support Arm	1	F012	3/8-16 Keps Nut		1
14	7028-30	Precleaner Tube, SD	1	F029	1/4-20 x 1/2 Hex Bolt		2
15	7028-2	Precleaner Tube, GHS	1	F035	5/16-18 x1-1/4 Hex Bolt		2
Engine Assembly				F038	3/8-16 x 1 Hex Bolt		1
16	NS	Seal, 7/16 (Kohler 4103202)	1	F050	1/4 SAE Washer		2
17	NS	20-hp Engine	1	F052	5/16 External Star Lock Washer		1
	NS	25-hp Engine (Optional or Exchange)	*	F061	1/4 Internal Star Lock Washer		2
	NS	26-hp EFI Engine (Optional or Exchange)	*	F063	3/8 Internal Star Lock Washer		2
18	NS	Wing Nut (Kohler 1210001)	1	F091	5/16-18 x 5/8 Hex Bolt		2
19	NS	Cover (Kohler 2409610) (Includes Item #20)	1	F106	3/8-16 x 5/8 Hex Bolt		2
20	NS	Air Cleaner Cover Seal (Kohler 2474318)	1	F175	1/2 Split Lock Washer		4
21	NS	Seal, 3/4 (Kohler 230046)	1	F184	1/4-20 x 1/2 Hex Bolt SS		6
22	NS	Bracket (Kohler 2412622)	1	F185	1/4 Internal Star Lock SS		6
23	NS	Base (Kohler 2409405)	1	F255	5/16-18 x 1-1/2 Hex Bolt		1
24	NS	Gasket (Kohler 2404106)	1	F273	M6 x 1.0 Nut		4
25	8015-1	Fuel Line, Engine	**	F274	M6 x 1.0 45 Stud		2
26	5879-3	Hose Clamp (1/2)	4	F285	1/2-13 x 1-1/2 Hex Bolt		4
27	NS	Oil Filter (Kohler 1205001)	1	F324	M8 x 1.25 x 12 Hex Bolt		2
28	5832	Cable Clamp (1/4) (Uses Existing Fasteners at Engine)	3				
29	8010-6	Valve Cover Sleeve	2	* May be ordered as a factory-installed option for dealer installation. Contact your Walker dealer.			
30	8010-2	Engine Bumper Mount	1	** Service Part Only			
31	5845	Bumper, Tapered (1.50 OD x 1.25)	1	NOTE: Item 14 is used only on SD Models. Item 15 is used only on GHS Models. Both items use existing fasteners at clutch lever.			
32	5020	Fuel Filter	**	NOTE: Items #16 & 18-24 are available as a complete kit by ordering Kohler P/N 2477521.			
Fuel Tank Assembly				NOTE: Refer to Kohler Engine Decal (NS) for Engine Identification Numbers.			
33	8015	Fuel Line, Tank	1				
34	5083	Fuel Shut-Off Valve	**				
35	5083-1	Bushing, Rubber	**				
36	8023	Fuel Tank Support	1				
37	8046	Fuel Tank, 4.3 Gallon, Gas (Includes Items # 26, 34, 35, 38 & 39)	1				
38	5082-2	Fuel Cap Seal	**				
39	5082	Fuel Tank Cap (Includes Item # 38)	**				

Use only genuine **Walker®** replacement parts.

Effective Date 3/29/00

ENGINE GROUP

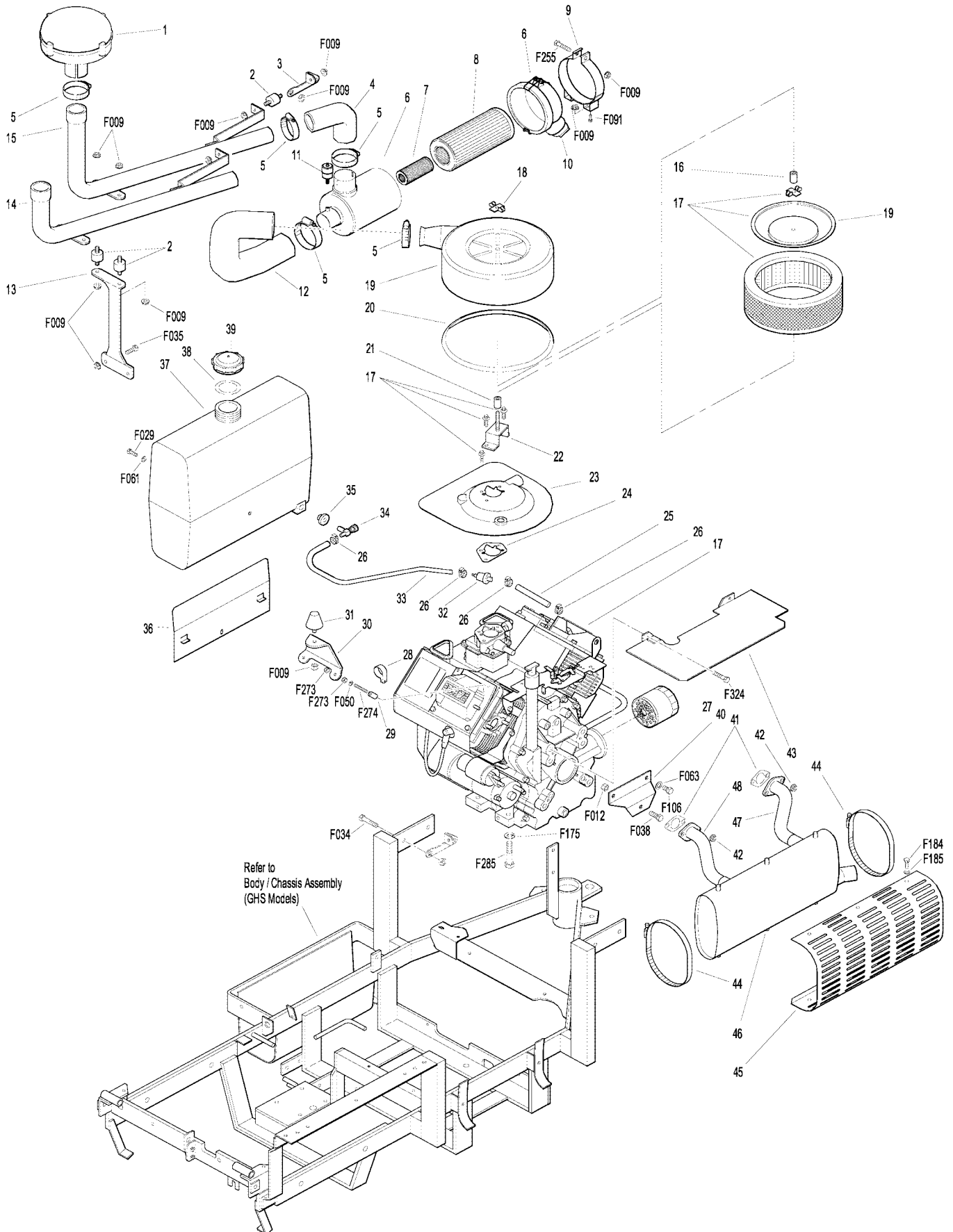

HYDROSTATIC GROUND DRIVE ASSEMBLIES

ITEM NO.	PART NO.	DESCRIPTION	NO. REQ'D	ITEM NO.	PART NO.	DESCRIPTION	NO. REQ'D
Transmission Lockout Assembly				Transmission Repair Parts			
1	5027	Lockout Mount	2	24	5025-5	Input Shaft	*
	5028-3	Transmission Lockout Assembly (Includes Items # 1, 2, 3, 4, F023 & F027)	*	25	5025-8	Bearing, Input	*
2	5028	Lockout Lever	2	26	5025-7	Snap Ring	*
3	5057-2	Lockout Cam (Includes Item # F081)	2	27	5025-2	Seal, Input Shaft	*
4	5847	Plastic Tip, Lockout Lever	2	28	5022	Reservoir to Casting Gasket	*
				29	5024	Reservoir Cap and Gasket	*
				30	5023	Transmission Reservoir Kit	*
				31	5023-1	Rubber Bladder	*
				32	5025-6	O-Ring & Plug Assembly	*
				33	5025-3	Seal, Control Shaft	*
Ground Drive Assemblies				Fasteners			
5	6209-1	Bridge Assembly	1	F012	3/8-16 Keps Nut		1
6	6243-2	Hydro Fan, CCW	1	F023	10-24 ESNA Nut		2
7	5026	Hydrostatic Drive, CW (700-031)	1	F027	10-24 x 5/8 PPHMS		2
8	6206	Pressure Relief Valve	*	F036	1/4-20 x 1/2 SBH Screw		2
9	6200-5	Gear Axle Drive Assembly (Includes Item # 8)	2	F038	3/8-16 x 1 Hex Bolt		4
10	5126	Cable Retainer	1	F043	3/8-16 x 3 Hex Bolt		7
11	6233-1	Pinion Gear	2	F053	7/16 Internal Star Lock Washer		4
12	6234	Spacer, Pinion Gear	2	F063	3/8 Internal Star Lock Washer		12
13	6201	O-Ring Seal	2	F064	1/8 x 1/2 Woodruff Key (# 3)		6
14	7244	Hydro Pulley (3-7/8)	2	F081	A/A45D Aluminum Pop Rivet		2
15	6243-1	Hydro Fan, CW	1	F160	External Snap Ring (.669 Shaft)		2
16	5025	Hydrostatic Drive, CCW (700-032)	1	F178	1/4 x 1 Fender Washer		2
				F194	7/16 x 1-1/4 x 1/8 Washer		2
				F200	7/16-20 x 3 Grade 8 Bolt		2
				F205	5/16-18 x 1/4 Set Screw, Knurl Point		4
				F244	7/16-20 x 3/4 Hex Bolt		2
				F262	3/8-16 x 4 Hex Bolt (Spec) All Thread		1
Deck Support Arm Assemblies				* Service Part Only			
17	6430-10	Outboard Mount, LH	1				
18	6430-2	Deck Support Arm, LH (Includes Item # 22)	1				
19	5775-2	Hitch Pin (# 6)	2				
20	6430-1	Deck Support Arm, RH (Includes Item # 22)	1				
21	6430-9	Outboard Mount, RH	1				
22	5830	Grease Fitting	2				
23	6840-1	Support Arm Bushing	2				

STEERING CONTROL ASSEMBLIES

ITEM NO.	PART NO.	DESCRIPTION	NO. REQ'D	ITEM NO.	PART NO.	DESCRIPTION	NO. REQ'D
Transmission Spring Assemblies				33	5280	Clevis (1/4)	1
1	6199	Transmission Spring Assembly (RH) (Includes Items # 2-8, F003, F287, F293 & F320)	*	34	5219	FSC Extension Spring (3/4 x 6-3/4)	1
2	5552	Ball Joint (1/4-28)	2	35	5142-2	FSC Actuator Cam	1
3	5192	Spring Plunger	2	36	5172	Bearing, Nylon (.255 ID x .379 OD x .250)	1
4	5194	Plunger Sleeve	2	37	5173	FSC Actuator Rod (Includes Items # 32 & F003)	1
5	6191	Spring Slide (4-3/4)	1	38	5975-3	Cable Tie (50# x 7")	1
6	5195	Compression Spring (1 x 5-1/8)	2	39	7170	FSC Lever Assembly (Includes Item # 22)	1
7	6196	Spring Slide Cap	1	40	5862	FSC Knob	1
8	5193	Washer (.750 ID x 1.00 OD x .085)	2	Fasteners			
9	5197	J-Bolt	1		F003	1/4-28 Hex Nut	3
10	5191	Spring Slide (3-5/8)	1		F004	1/4-20 Keps Nut	9
11	5199	Transmission Spring Assembly (LH) (Includes Items # 2-4, 6, 8-10, F003, F146, F287 & F293)	*		F007	5/16-18 Jam Nut	1
Steering Lever & FSC Assemblies					F008	5/16-24 Keps Nut	2
12	6212	Transmission Control Arm, RH	1		F009	5/16-18 Whiz Locknut	1
13	5141	FSC Friction Washer	2		F010	5/16-24 ESNA Nut	2
14	5140	FSC Friction Body (Includes Item # 22)	1		F012	3/8-16 Keps Nut	2
15	5142-5	FSC Key	1		F024	5/16-24 Jam Nut	2
	5140-3	FSC Control Assembly (Includes Items # 13, 14, 15, 22, 34, F192 & F193)	*		F029	1/4-20 x 1/2 Hex Bolt	2
16	5214-2	Ball Joint (5/16-24), Nylon Lined	2		F032	1/4-20 x 3/4 Hex Bolt	3
17	5212-5	Transmission Control Arm, LH	1		F034	5/16-18 x 3/4 Hex Bolt	1
18	5850-2	Handle Grip, Foam (5-1/2)	2		F050	1/4 SAE Washer	3
19	5213-1	Control Rod, LH (15")	1		F051	3/8 SAE Washer	2
20	5223	Extension Spring (1/4 x 5-1/2)	2		F064	1/8 x 1/2 Woodruff Key (# 3)	2
21	5450	D-Clip	2		F068	1/8 x 1 Cotter Pin	1
22	5830	Grease Fitting	6		F069	3/32 x 1/2 Cotter Pin	1
23	5214-1	Bearing, Steering Lever Actuator	2		F093	5/16-18 x 1 Hex Bolt	1
24	5463	Steering Lever Actuator	2		F104	1/4-20 x 3/4 PFH Bolt	1
25	5451-3	Steering Lever Assembly, LH (Includes Items # 18, 22, 26, F188, F198 & F345)	1		F134	AN960816L Washer	2
	5451-5	Adjustable Steering Lever Arm, LH	1		F146	1/4-20 Jam Nut	1
26	5453-10	Adjustable Steering Lever Handle (Includes Items # 18 & F345)	2		F182	1/4 x 5/8 x 1/8 Washer	2
27	5391-3	Steering Lever Support	1		F183	.312 x .700 x .074 Washer	2
28	5217	Pivot Pin, Steering Lever	1		F186	5/64 x 1/2 Cotter Pin	1
29	5470-1	Speed Control Stop	1		F188	1/4-20 Self-Locking Nut	4
30	5450-3	Steering Lever Assembly, RH (Includes Items # 18, 22, 26, F188, F198 & F345)	1		F192	3/8-24 Self-Locking Nut	1
	5450-5	Adjustable Steering Lever Arm, RH	1		F193	3/8 Belleville Spring Washer	3
31	5213-2	Control Rod, RH (6")	1		F198	.250 x .625 x .040 Washer, SS	4
32	5281-5	Clevis Pin (1/4 x 0.80)	1		F287	1/4-28 Keps Nut	2
					F293	1/8 x 1 Roll Pin	2
					F320	1/8 x 3/4 Split Spring Pin	1
					F345	1/4-20 x .770 Knurled Bolt	4
				*	Service Part Only		

Use only genuine **Walker®** replacement parts.

Effective Date 3/29/00

STEERING CONTROL ASSEMBLIES

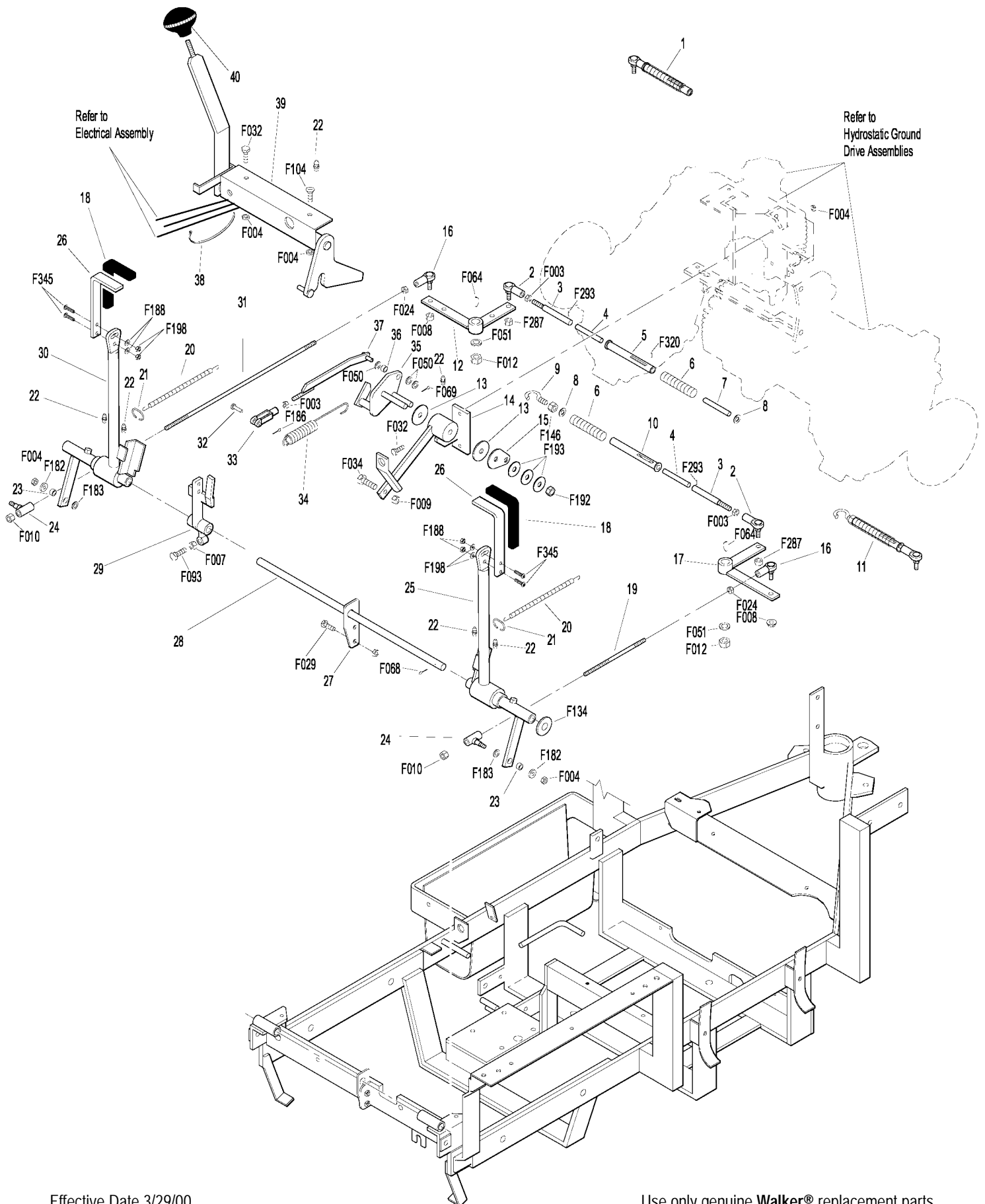

Effective Date 3/29/00

Use only genuine **Walker®** replacement parts.

THROTTLE & CHOKE CONTROL ASSEMBLY

ITEM NO.	PART NO.	DESCRIPTION	NO. REQ'D	ITEM NO.	PART NO.	DESCRIPTION	NO. REQ'D
Throttle & Choke Control Assemblies				Fasteners			
1	8121-1	Throttle Cable	1		F002	10-24 Keps Nut	6
2	8122-1	Choke Cable	1		F005	1/4-20 ESNA Nut	2
3	5172	Nylon Bearing	2		F025	10-24 x 3/8 PPHMS	4
4	5108-7	Control Lock Tab	2		F050	1/4 SAE Washer	2
5	5108-10	Friction Washer (.125)	2		F164	10-24 x 1/4 x 3/8 SHL Bolt	2
6	5108-1	Control Lever, Throttle & Cable	2		F201	1/4 Belleville Spring Washer	4
7	5108-5	Throttle Control Knob, Red	1				
8	5108-11	Friction Washer (.062)	2	*		Service Part Only	
9	5108-8	Control Bracket	2				
10	7108	Control Assembly, Throttle and Choke	2				
	8121	Complete Throttle Control and Cable Assembly (Includes Item # 7)	*				
	8122	Complete Choke Control and Cable Assembly (Includes Item # 11)	*				
11	5108-6	Choke Control Knob, Black	1				
12	8123	Insulation Sleeve (3/8 x 6)	1				
13	5975-1	Cable Tie (18# x 3-3/4)	2				

THROTTLE & CHOKE CONTROL ASSEMBLY

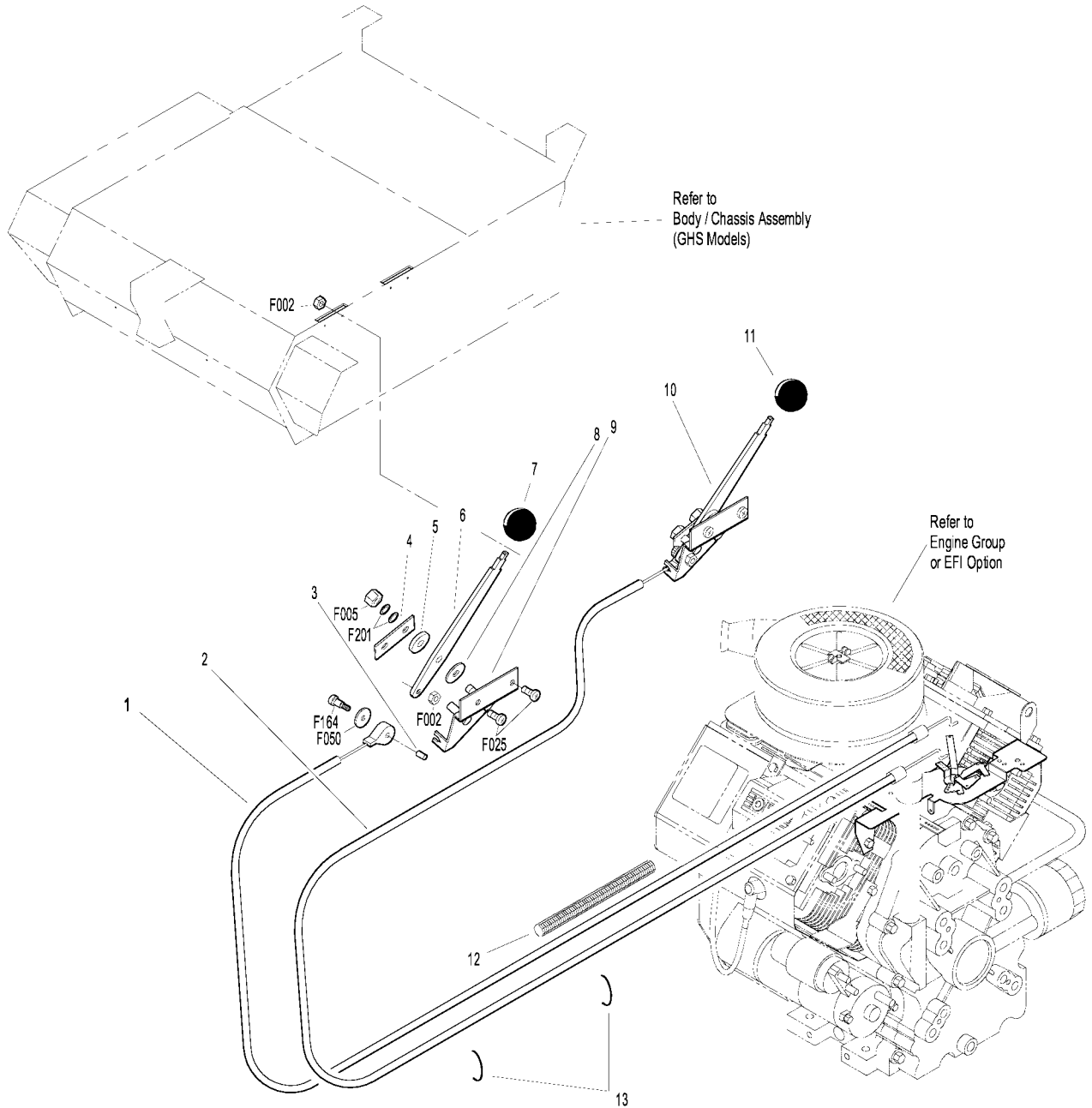

PARKING BRAKE ASSEMBLY

ITEM NO.	PART NO.	DESCRIPTION	NO. REQ'D	ITEM NO.	PART NO.	DESCRIPTION	NO. REQ'D
Parking Brake Assembly				Fasteners			
1	7406-1	Handle Grip, Red	1	F002		10-24 Keps Nut	2
2	7406-8	Parking Brake Lever	1	F003		1/4-28 Hex Nut	2
3	7406-2	Lever Mount	1	F004		1/4-20 Keps Nut	4
4	5830	Grease Fitting	1	F025		10-24 x 3/8 PPHMS	2
5	7407	Clevis Pin (3/16 x 1/2)	2	F029		1/4-20 x 1/2 Hex Bolt	3
6	7404	Brake Actuator Arm	2	F032		1/4-20 x 3/4 Hex Bolt	1
7	7405	Pin, Transmission Lock	2	F054		AN960616 Washer	1
8	7402	Clevis	2	F061		1/4 Internal Star Lock Washer	1
9	7408	Compression Spring (1/2 x 3/4)	2	F072		1/4 "E" Retainer Ring	2
10	7415	Rubber Dust Shield (5/8 x 3/8 x 1/32)	2	F086		# 10 SAE Washer	4
11	5567-3	O-Ring Seal (1/4 x 3/8)	4	F109		1/8 x 5/8 Roll Pin	2
12	7403	Plunger Bushing, Gear Axle	2	F111		1/8 x 3/4 Cotter Pin	1
13	7404-1	Brake Actuator Mount	2	F112		5/8 x 1-1/4 x .03 Washer	2
14	7412	Clevis Pin (3/16 x 3/4)	2	F127		1/16 x 1/2 Cotter Pin	4
15	5833	Cable Clamp (1/4)	2	F261		AN960616L Washer	6
16	7409	Brake Control Cable, RH (21")	1				
17	7410	Brake Control Cable, LH (27")	1				
18	7401-3	Cable Mount Bracket	1				
19	7401-1	Cable Pull Rod	1				
20	5552	Ball Joint (1/4-28)	1				

PARKING BRAKE ASSEMBLY

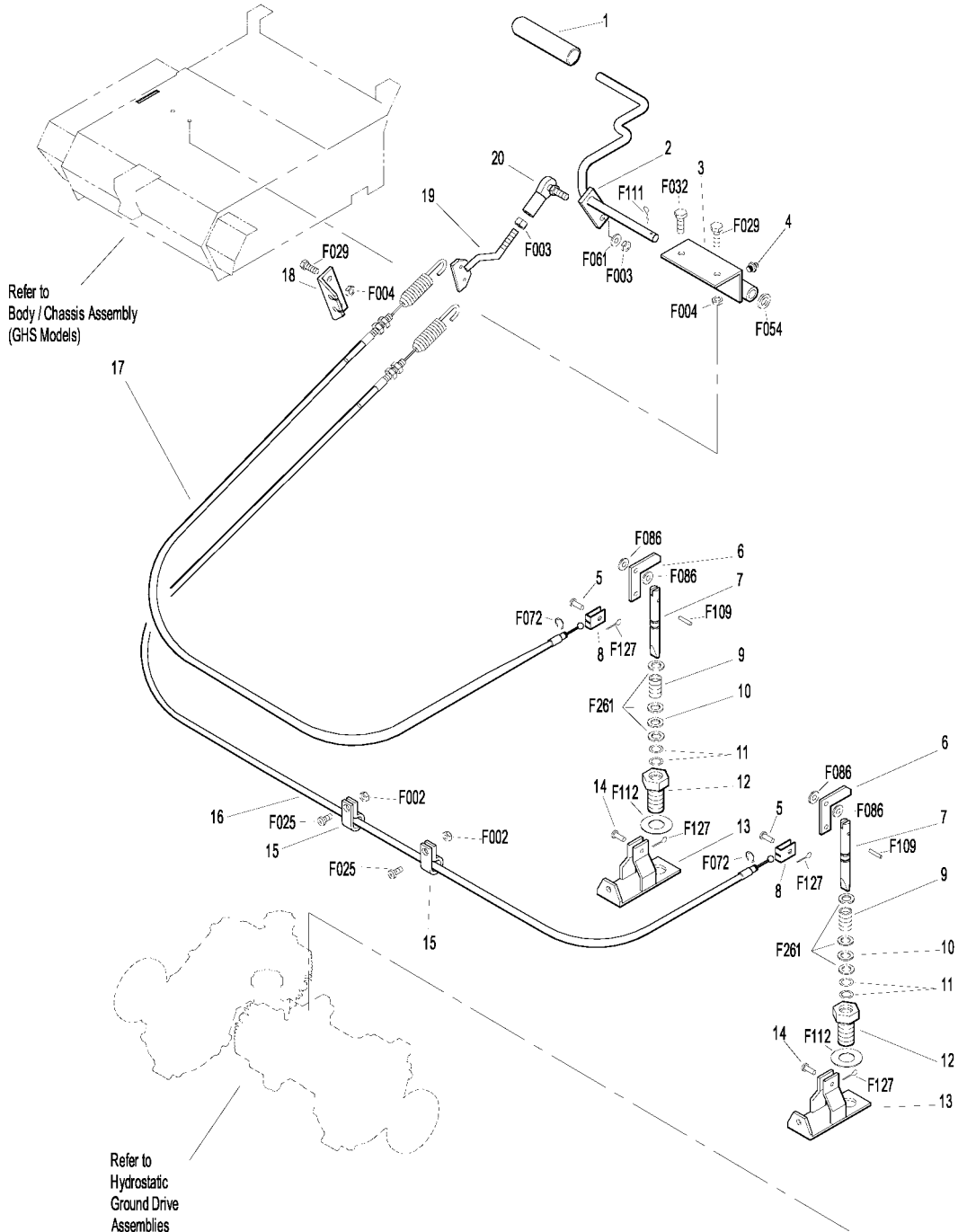

GHS GROUP

ITEM NO.	PART NO.	DESCRIPTION	NO. REQ'D	ITEM NO.	PART NO.	DESCRIPTION	NO. REQ'D
Delivery Chute Assembly				Fasteners			
1	5515-7	Elbow Delivery Spout Insert	1	F002		10-24 Keps Nut	8
	5515-2	Elbow Delivery Spout Assembly (Includes Items # 1 and F331)		F004		1/4-20 Keps Nut	6
2	5980-3	Wire, Grass-Pak Switch	1	F009		5/16-18 Whiz Locknut	1
3	5833	Cable Clamp (1/4)	2	F012		3/8-16 Keps Nut	3
4	5592-11	Liquid Tight Plug	1	F026		10-24 x 1/4 PPHMS	2
5	5594-5	Vane Assembly, Grass Pak Switch (Includes Items # F144 & F145)	1	F034		5/16-18 x 3/4 Hex Bolt	1
6	5592-5	Grass-Pak Switch Module	1	F038		3/8-16 x 1 Hex Bolt	1
7	5592-12	Mount Plate, Grass-Pak Switch	1	F040		3/8-16 x 1-1/2 Hex Bolt	1
8	5975-3	Cable Tie (# 50 x 7")	1	F042		3/8-16 x 2-1/4 Hex Bolt	1
9	5592-13	Backing Plate, Grass-Pak Switch	1	F054		AN960616 Washer	1
10	5578	Rear Clip, Chute Mount	1	F067		3/16 x 3/16 x 1 Key	1
11	5577	Side Clip, Chute Mount	2	F074		1/4-20 x 3/8 Set Screw	2
12	7511-1	7.0 Delivery Chute Assembly (Includes Items # 10, 11, F079 & F085)	1*	F075		5/16-18 x 1/2 SQH Set Screw	1
13	7530	Body Chute	1	F079		A/A66D Aluminum Pop Rivet	14
				F085		3/16 Rivet Backup Washer	8
				F102		10-24 x 1-1/2 PTHMS	2
				F114		5/16-18 x 5/8 SQH Set Screw	2
				F128		10-24 x 3/8 PTHMS	4
				F144		4-40 x 1/4 PPHMS	1
				F145		4-40 Keps Nut	1
				F163		5/16-18 x 3/4 SQH Set Screw	1
14	7238	Blower Drive Pulley (4-1/4 / 3V)	1	F217		7/16-14 Hex Nut	1
15	7234	Blower Belt (3VX280)	1	F218		7/16 Split Lock Washer	1
16	7239	Blower Pulley (3-3/8 / 3V)	1	F219		7/16-14 x 1-1/4 Hex Bolt	1
17	7201-3	DU Bearing	2	F231		1/4 x 3/4 Woodruff Key (# 806)	1
18	7201-4	Inner Race (1-1/2)	1	F331		3/16 D x 1/4 L Rivet Semi-Tie	5
19	5221	Extension Spring (3/4 x 4)	1				
20	7364	Blower Belt Tightener Arm	1				
21	5841	Retainer Washer	1				
Blower Belt Tightener Assembly							
Blower Assembly							
22	7245	Idler Pulley (1/2 Groove)	1				
23	5268	Bearing (3/4) Includes Locking Collar	2				
24	6543	Housing (10" Blower)	1				
	6542	Blower Assembly (10")	**				
25	6545	Blower Wheel (10")	1				
26	6525-2	Faceplate (10" Blower)	1				
27	6526	Intake Tube (6-1/2 x 2-1/2)	1				
28	5595-2	Intake Cover	***				
29	7833	Cable Clamp (7/8 x 1/4)	1				
30	7528	Skid Bar (10" Blower)	1				

* For use on GHS 7.0 Bushel Catcher Assembly. When Optional 9.5 Bushel Catcher Assembly is purchased, this part is replaced by P/N 8511-1 (Delivery Chute Assembly, 9.5). Refer to **OPTIONAL GHS 9.5 BUSHEL CATCHER ASSEMBLY**, Page 30.

** Service Part Only

*** Plugs Blower when GHS is not in use. Furnished only with Mulching Decks, SD Decks used on a GHS Tractor, Rotary Broom Attachment and Snowblower Attachment.

NOTE: Refer to **ELECTRICAL CONNECTORS**, Page 36 for identification of all Electrical Wiring Service Parts.

GHS POWERFIL® ASSEMBLY

ITEM NO.	PART NO.	DESCRIPTION	NO. REQ'D	ITEM NO.	PART NO.	DESCRIPTION	NO. REQ'D
GHS Powerfil® Assembly				Fasteners			
1	5557	Motor Mount, Powerfil®	1	F002		10-24 Keps Nut	13
2	5551-3	Bearing Cap, Powerfil®	1	F003		1/4-28 Hex Nut	4
3	5551-1	Pivot Bearing (# S3PP)	2	F025		10-24 x 3/8 PPHMS	2
4	5552	Ball Joint (1/4-28)	2	F054		AN960616 Washer	1
5	5857	Wire Clamp (1/8 J-Clip)	2	F061		1/4 Internal Star Lock Washer	1
6	5518-2	Pivot, Delivery Spout	1	F085		# 10 SAE Washer	1
7	5517-2	Pivot Mount	1	F101		10-24 x 1-1/4 SHC Screw	1
8	5558-1	Powerfil® Push Rod	1	F109		1/8 x 5/8 Roll Pin	1
9	5553-3	Bushing, Powerfil® Actuator	4	F129		10-24 x 1/2 PTHMS	10
10	5558-2	Powerfil® Actuator Rod	1	F261		AN960616L Washer	1
	5549-20	Actuator Rod Assembly (Includes Items # 4, 8, 9, 10, 11 & F003)	*	* Service Part Only			
11	5553-1	Spring, Powerfil® Actuator	2				
12	5554	Actuator Arm	1				
13	5519-3	Motor Mount Nut (5/8-24 Panel Nut)	*				
14	5519-2	Motor Mount Washer	*				
15	5519	Actuator Motor (12/24V) (Includes Items # 13 & 14)	1				
16	5977	Grommet (1/2 ID x 7/8 OD x 1/16)	1				

Use only genuine **Walker®** replacement parts.

Effective Date 3/29/00

GHS 7.0 BUSHEL CATCHER & EXHAUST DEFLECTOR ASSEMBLIES

ITEM NO.	PART NO.	DESCRIPTION	NO. REQ'D
Upper Baffle Screen Assembly (Removable)			
1	7509-3	Channel Bottom	2
2	7505	Mustache Spring	2
3	7507	7.0 / 9.5 Screen Seal, (27-1/2)	1
4	7856-1	7.0 / 9.5 Edge Molding, (26")	1
5	7509-2	Channel Top	2
6	7512-2	7.0 / 9.5 Removable Screen	1
7	7506	Knob	2
8	7509-4	7.0 / 9.5C-Channel	1
Exhaust Deflector Assembly			
9	7504-3	Hinge, Exhaust Deflector	1
10	7504-1	Exhaust Deflector (Two Piece Set)	1
11	7504-8	Deflector Mount Doubler	2
GHS 7.0 Bushel Catcher Assembly			
12	5583	Handle	1
13	5588	Rubber Bumper (.75 OD x .50)	2
14	7522	7.0 Side Strap, Door	2
15	7514-10	7.0 Door Frame, Catcher	1
16	7510-1	7.0 Bushel Catcher, Including Door	1
	7502-1	7.0 Catcher Assembly, Without Powerfil® (Includes Door)	*
	7502-2	7.0 Catcher Assembly (Includes Powerfil®)	*
	7502-3	7.0 Catcher Assembly (Includes Frame & Powerfil®)	*
17	7514-1	Backup Plate, Catcher Door	1
18	7610	Catcher Dump Plate	1
19	7610-1	Dump Plate Slide	2
20	7503	7.0 Mounting Frame, Catcher	1
21	5281-5	Clevis Pin (0.25 x 0.80)	2
22	7513-2	7.0 Mounting Frame Doubler	1
23	5155-12	5/16 Ball Stud	2
24	5147	Spring Clip, Gas Spring	4
25	5155	Catcher Gas Spring Assembly (Includes Items # 23, 24 & 27)	2
26	5524-1	Flanged Hinge Bearing	2
27	5155-13	3/4 Ball Stud	2
28	5523-6	Gas Spring Plate	2
29	7532	Handle, Catcher Lift	2
30	7533	Backing Plate, Handle	2
31	5155-15	Box Support, Gas Spring	2
32	5522-1	Hinge Backup Plate, LH	1
33	7557-10	7.0 Wire Harness Channel	1
34	5976-2	Grommet (3/16 ID x 3/4 OD)	1
35	5976	Grommet (3/8 ID x 3/4 OD)	1
36	5522-2	Hinge Backup Plate, RH	1
37	7508	7.0 / 9.5 Safety Latch Hinge	1
38	7584	Reinforcing Strap, Catcher Top	2

ITEM NO.	PART NO.	DESCRIPTION	NO. REQ'D
5598 Optional Dump Bag (Not Shown)**			
Fasteners			
	F002	10-24 Keps Nut	27
	F004	1/4-20 Keps Nut	17
	F009	5/16-18 Whiz Locknut	2
	F020	5/16-18 ESNA Nut	2
	F025	10-24 x 3/8 PPHMS	4
	F027	10-24 x 5/8 PPHMS	4
	F035	5/16-18 x 1-1/4 Hex Bolt	1
	F037	10-24 x 5/8 PTH Screw	6
	F049	5/16 SAE Washer	7
	F061	1/4 Internal Star Lock Washer	2
	F069	3/32 x 1/2 Cotter Pin	2
	F079	A/A66D Aluminum Pop Rivet	34
	F085	3/16 Rivet Backup Washer	23
	F129	10-24 x 1/2 PTHMS	10
	F172	1/4-20x3/4 Carriage Bolt	4
	F188	1/4-20 Self Locking Nut	17
	F195	1/4-20 x 3/4 PPHMS SS	16
	F196	1/4-20 x 1 PPHMS SS	3
	F198	.625 x .250 x .040 Washer, SS	13
	F223	3/16 x 5/16 Semi-Tube Rivet	4
	F224	3/16 x 7/16 Semi-Tube Rivet	4
	F228	# 6 x 1/2 PPHSM Set Screw	2
	F230	1/4-20 x 1-1/4 PPHMS SS	1
	F242	1/4-20 x 7/8 PPHMS SS	11
	F252	10-24 x 3/4 PPHMS	1
	F255	5/16-18 x 1-1/2 Hex Bolt	1
	F329	.260 ID x 1.939 OD Washer	2
	F330	3/16 D x 21/32 Rivet, SS	2
	F331	3/16 D x 1/4 L Semi-Tube Rivet	1
	F340	Rivet, Aluminum	1
	F351	Aluminum Pop Rivet	6

* Service Part Only

** Not used with Power Dump Option. Contact your Walker dealer to order Optional Dump Bag.

Use only genuine **Walker®** replacement parts.

Effective Date 3/29/00

GHS 7.0 BUSHEL CATCHER & EXHAUST DEFLECTOR ASSEMBLIES

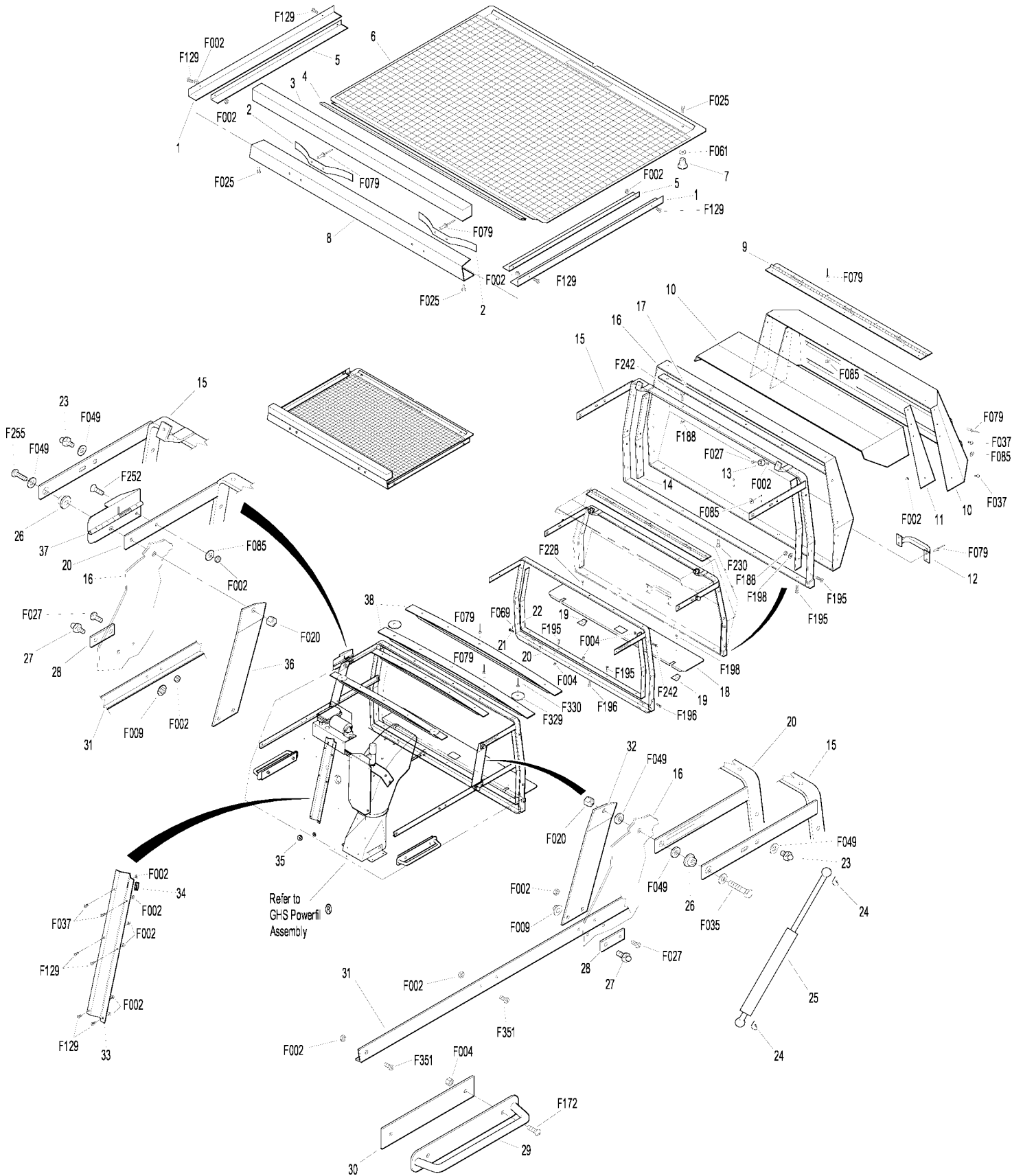

Effective Date 3/29/00

Use only genuine Walker® replacement parts.

GHS 9.5 BUSHEL CATCHER ASSEMBLY

ITEM NO.	PART NO.	DESCRIPTION	LOCATION		NO. REQ'D. GHS	NO. REQ'D SD
GHS 9.5 Bushel Catcher Assembly*				Fasteners		
1	7584	Reinforcing Strap, Catcher Top	2	F002	10-24 Keps Nut	17
2	8510-1	9.5 Bushel Catcher, Including Door	1	F004	1/4-20 Keps Nut	19
	8502-1	9.5 Catcher Assembly, Without Powerfil® (Includes Door)	**	F009	5/16-18 Whiz Locknut	2
				F020	5/16-18 ESNA Nut	2
	8502-2	9.5 Catcher Assembly (Includes Powerfil®)	**	F027	10-24 x 5/8 PPHMS	4
				F035	5/16-18 x 1-1/4 Hex Bolt	1
	8502-4	9.5 Catcher Assembly (Includes Frame & Powerfil®)	**	F037	10-24 x 5/8 PTH Screw	2
				F049	5/16 SAE Washer	8
3	5583	Handle	1	F069	3/32 x 1/2 Cotter Pin	2
4	8514-10	9.5 Door Frame, Catcher	1	F079	A/A66D Aluminum Pop Rivet	26
5	8516	Backup Plate, Door Sides	2	F085	3/16 Rivet Backup Washer	13
6	5155-12	5/16 Ball Stud	2	F129	10-24 x 1/2 PTHMS	4
7	5588	Rubber Bumper (.75 OD x .50)	2	F172	1/4-20 x 3/4 Carriage Bolt	4
8	7514-1	Backup Plate, Catcher Door	1	F188	1/4-20 Self Locking Nut	20
9	5147	Spring Clip, Gas Spring	4	F195	1/4-20 x 3/4 PPHMS SS	4
10	5155	Catcher Gas Spring Assembly (Includes Items # 6, 9, & 14)	2	F196	1/4-20 x 1 PPHMS SS	3
				F198	.625 x .250 x .040 Washer, SS	5
11	5522-1	Hinge Backup Plate, LH	1	F203	1/4-20 x 5/8 PPHMS SS	4
12	5524-1	Flanged Hinge Bearing	2	F230	1/4-20 x 1-1/4 PPHMS SS	1
13	5523-6	Gas Spring Plate	2	F242	1/4-20 x 7/8 PPHMS SS	23
14	5155-13	3/4 Ball Stud	2	F252	10-24 x 3/4 PPHMS	1
15	5155-15	Box Support, Gas Spring	2	F255	5/16-18 x 1-1/2 Hex Bolt	1
16	7533	Backing Plate, Handle	2	F329	.260 ID x 1.939 OD Washer	2
17	7532	Handle, Catcher Lift	2	F330	3/16 D x 21/32 L Rivet, SS	2
18	8117	9.5 Wire Harness Channel	1	F351	Aluminum Pop Rivet	6
19	5976	Grommet (3/8 ID x 11/16 OD)	2			
20	5522-2	Hinge Backup Plate, RH	2			
21	7508	7.0 / 9.5 Safety Latch Hinge	1			
22	8503	9.5 Mounting Frame, Catcher	1			
23	5281-5	Clevis Pin (1/4 x .080)	2			
24	8513-2	9.5 Mounting Frame Doubler	1			

* May be ordered as a factory-installed option. Contact your Walker dealer.

** Service Part Only

NOTE: Refer to **ELECTRICAL CONNECTORS**, Page 36 for identification of all Electrical Wiring Service Parts.

GHS 9.5 BUSHEL CATCHER ASSEMBLY

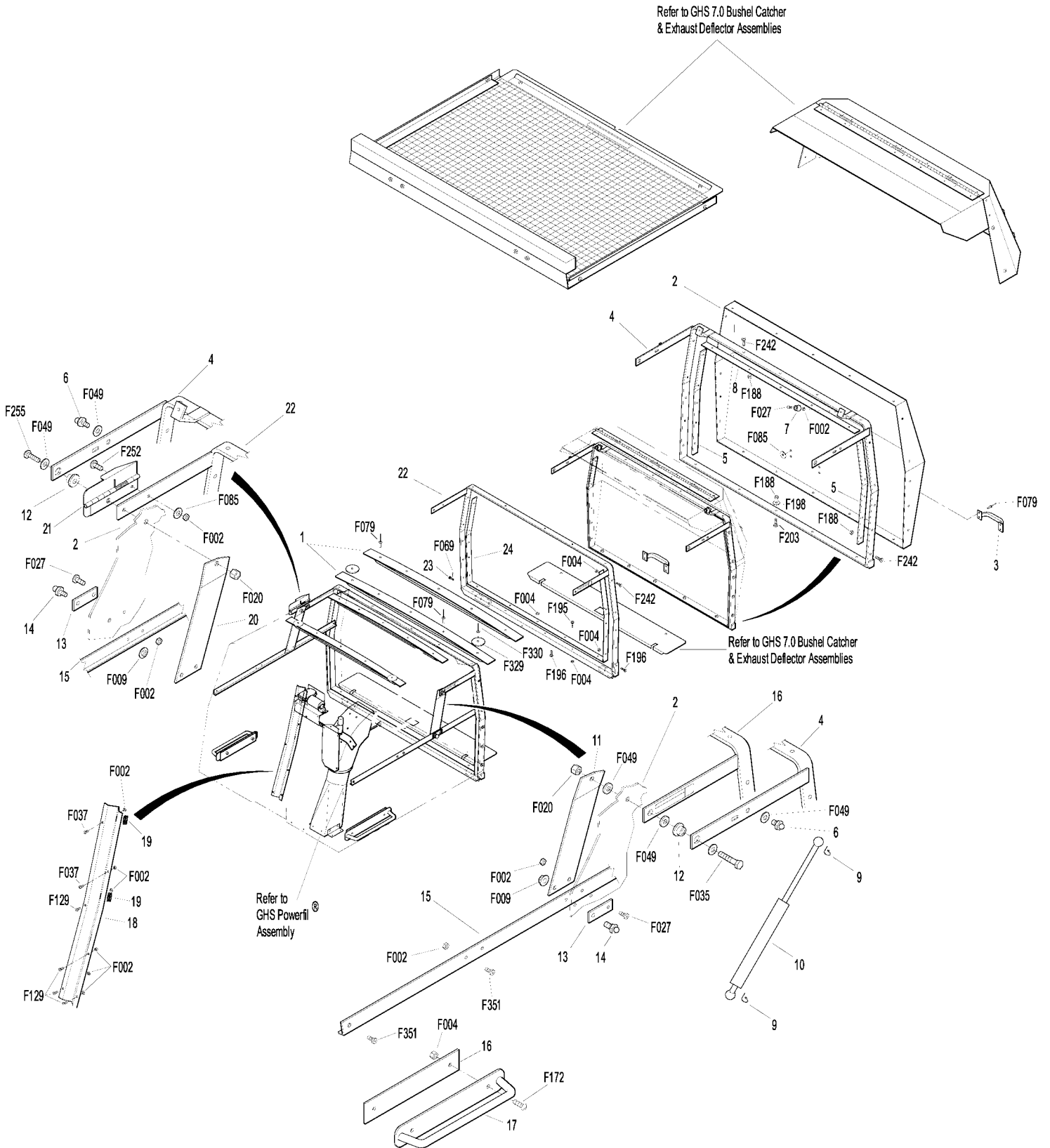

INSTRUMENT PANEL ASSEMBLY

ITEM NO.	PART NO.	DESCRIPTION	NO. REQ'D	ITEM NO.	PART NO.	DESCRIPTION	NO. REQ'D
Instrument Panel Assembly				17	5975-1	Cable Tie (18# x 3-3/4)	2
1	7307-2	Instrument Panel Cover (Optional)	*	18	8945-1	Wire Harness, Instrument Panel	1
	8306	Instrument Panel Assembly (Includes Items # 2-4, 6-9, 11-15, 19, F062, F250 & F251)	1	19	7391	Panel Box Mount Plate	2
2	7307	Panel Frame	1	20	7307-1	Shock Mount (1.0 OD x .25)	3
3	8960-2	Ignition Key (1 Set)	**	21	8385	Panel Box	1
4	8960	Ignition Switch (with Keys) (Includes Item # 3)	1	22	8536	Warning Horn	1
5	7854	Tip, Red	1	23	7307-15	Foam Insert, Panel Box	1
6	8996-4	Red Indicator Lens	2	Fasteners			
7	8996-3	Indicator Bulb (Replacement for P/N 8996-2)	**	F004	1/4-20 Keps Nut		6
8	8996-2	Red Indicator Light Assembly (Includes Item # 7)	2	F062	# 8 Internal Star Lock Washer		2
9	8997	Voltmeter Gauge	1	F228	# 6 x 5/8 PPHSMS, SS		8
10	8990	Hourmeter	1	F238	J Clip, Instrument Panel C15520-6A		8
11	5995-2	Switch Boot (Fits P/N 5995)	1	F250	6-32 x 3/8 PPHMS		2
12	8823-1	Decal, Instrument Panel	1	F251	6-32 Keps Nut		2
13	8820-10	Panel Faceplate	1	F349	Washer .835 ID 1.122 OD, SS		1
14	7386	Panel Gasket	1	* May be ordered as an option. Contact your Walker dealer.			
15	5995-1	Wire Terminal Adapter	1	** Service Part Only			
16	5995	Toggle Switch (Off-On)	1	NOTE: Refer to ELECTRICAL CONNECTORS , Page 36 for identification of all Electrical Wiring Service Parts.			

INSTRUMENT PANEL ASSEMBLY

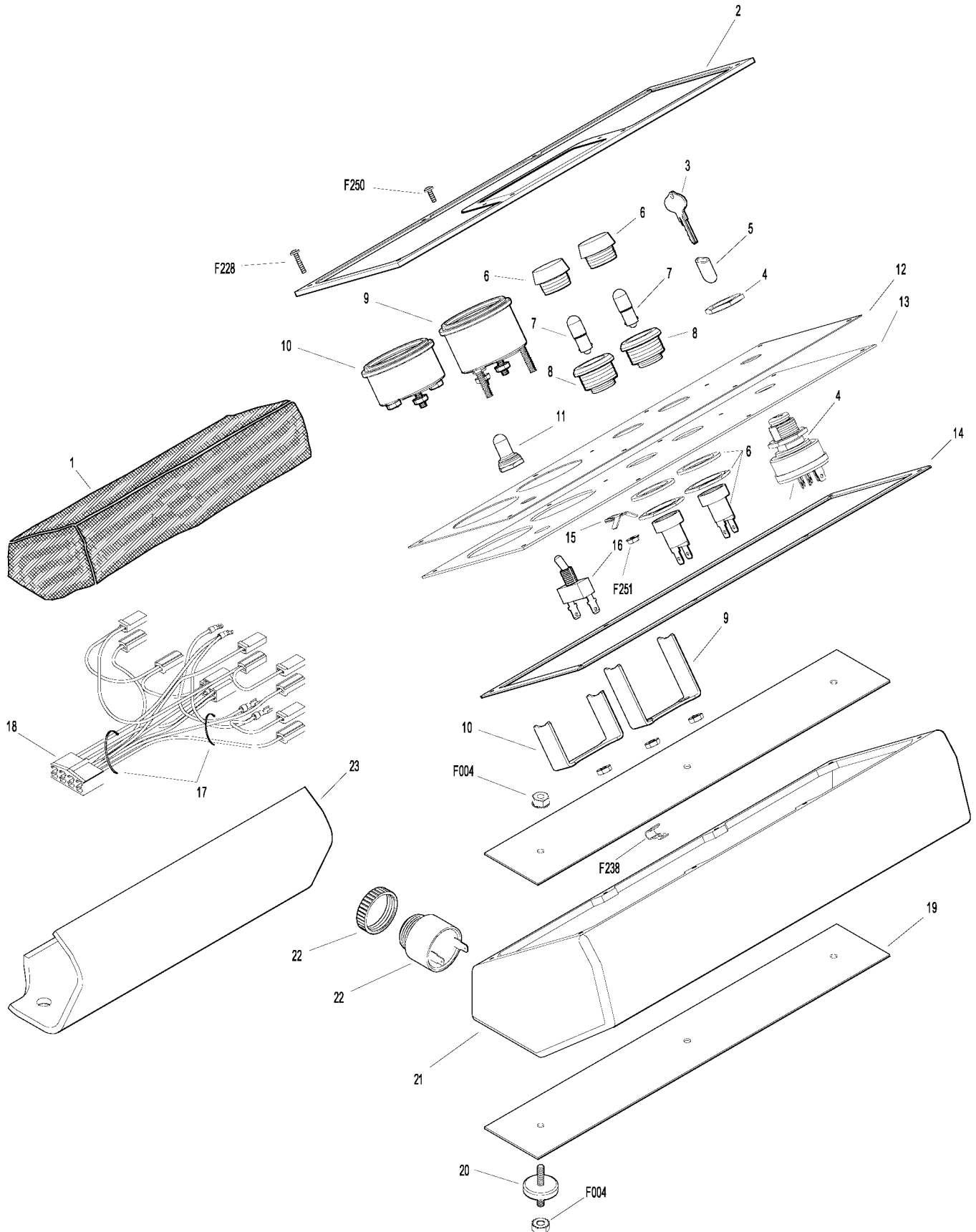

Effective Date 3/29/00

Use only genuine **Walker®** replacement parts.

ELECTRICAL ASSEMBLY

ITEM NO.	PART NO.	DESCRIPTION	NO. REQ'D	ITEM NO.	PART NO.	DESCRIPTION	NO. REQ'D
Electrical Assembly				28	8940-2	Wire Harness	1
1	6923	Negative Battery Cable	1	29	6390	Battery Pan	1
2	5975-1	Cable Tie (18# x 3-3/4)	5	30	6392	Battery Protector Plate	1
3	5932	Battery Terminal Insul., Black (-)	1	31	5839	Hook Bolt, Battery Mount	2
4	5910	Battery (12V U1-SP30, Dry)	1	32	5844	Battery Hold-Down Bar	1
5	5933	Battery Terminal Insul., Red (+)	1	Fasteners			
6	8943	Positive Battery Lead Wire (Red)	1		F002	10-24 Keps Nut	6
7	8941	Circuit Breaker (30 Amp) with Reset	1		F004	1/4-20 Keps Nut	5
8	6941	Relay Switch (30/40 Amp)	2		F009	5/16-18 Whiz Locknut	1
9	5976-2	Grommet (3/16 ID x 7/8 OD)	1*		F019	1/4-20 ESNA Wing Nut	2
10	5832	Cable Clamp (1/2)	8		F025	10-24 x 3/8 PPHMS	4
11	5975-3	Cable Tie (50# x 7") (GHS Models Use Only 3)	6		F027	10-24 x 5/8 PPHMS	1
12	7944	7.0 Wire Harness	1**		F029	1/4-20 x 1/2 Hex Bolt	1
	8950	9.5 Wire Harness	1**		F031	1/4-20 x 5/8 Hex Bolt	1
13	5536-2	Horn, Full Signal (GHS)	1*		F032	1/4-20 x 3/4 Hex Bolt	1
14	5961	Relay Fuse Mount	1		F050	1/4 SAE Washer	4
15	6941-1	20 Amp Fuse	1		F061	1/4 Star Washer	1
16	5940-6	Fuse Holder with Terminals	1		F078	A/A64D Aluminum Pop Rivet	7
17	8539	Starter Relay Mount	1		F093	5/16-18 x 1 Hex Bolt	1
18	8977	Grommet (1/8 x 7/8)	1		F124	10-32 x 3/8 Taptite Machine Screw	2
19	5941	Safety Switch (Normal Closed) (Includes Item # 20)	1		F284	M6 x 1.0 x 8 SHC Screw	1
20	5941-1	Switch Boot (Fits P/N 5941)	1	* GHS Models Only			
21	5975-5	Wire Clip, Self-Mount	2	** Used on GHS Models with 7.0 Bushel Catcher only. When Optional GHS 9.5 Bushel Catcher is purchased, this part is replaced by P/N 8950 (9.5 Catcher Wire Harness).			
22	5942	Safety Switch (Normal Open) (Includes Item # 23)	1	NOTE: Refer to ELECTRICAL CONNECTORS , Page 36 for identification of all Electrical Wiring Service Parts.			
23	5942-1	Switch Boot (Fits P/N 5942)	1				
24	5975-2	Cable Tie (30# x 6")	1				
25	7942	Safety Switch (Includes Item # 26)	1				
26	7942-0	Nut, Safety Switch (Fits P/N 7942)	1				
27	7942-15	Connector, Pigtail	1				

ELECTRICAL ASSEMBLY

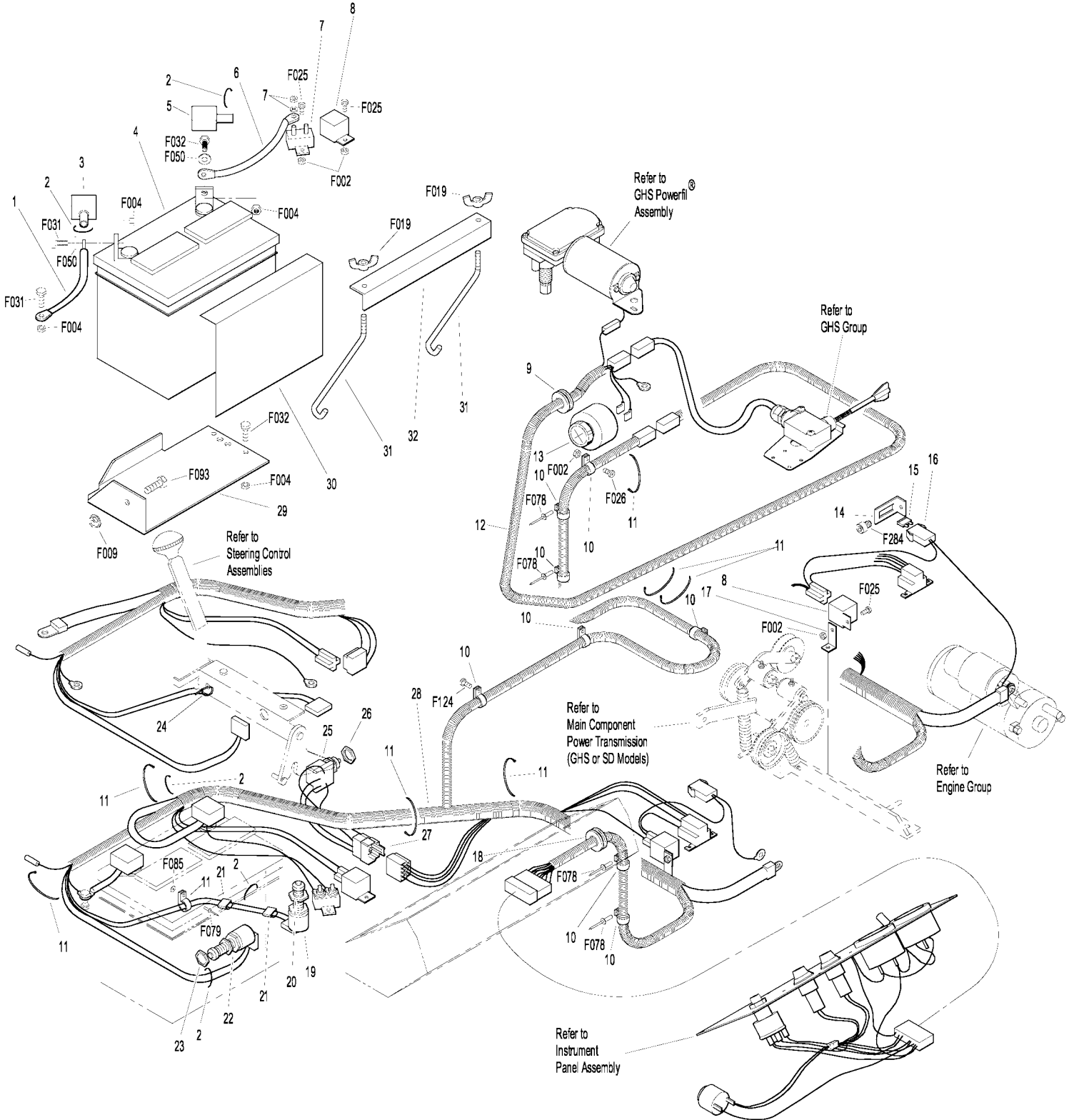

ELECTRICAL CONNECTORS

ITEM NO.	PART NO.	DESCRIPTION	NO. REQ'D	ITEM NO.	PART NO.	DESCRIPTION	NO. REQ'D
Electrical Wiring Service Parts				25	7942-2	2-Way Connector, Male	*
1	5996-1	16-14 GA Butt Conn.	*	26	7942-3	2-Way Connector, Female	*
2	5996-4	16-14 GA Bullet Conn., Male	*	27	7942-10	2-Way Locking Connector, Male	*
3	5996-5	16-14 GA Bullet Conn., Female	*	28	5940-8	3-Way Connector, Male	*
4	5940-4	16-14 GA Spg. Loaded Term., Female	*	29	7942-9	3-Way Connector, Male	*
5	5940-7	Brass Wire Clip, Female	*	30	8944	3-Way Locking Connector, Male	*
6	5996	1/4 x 16-14 GA QKS Term., Female	*	31	8944-1	3-Way Locking Connector, Female	*
7	5996-2	3/16 x 22-18 GA QKS Term., Female	*	32	7942-11	4-Way Connector, Male	*
8	7996	3/16 x 16-14 GA QKS Term., Female	*	33	7942-12	4-Way Connector, Female	*
9	5940-5	16-14 GA Spg. Loaded Term., Male	*	34	7942-5	5-Way Connector, Male	*
10	5996-0	1/4 x 22-18 GA QKS Term., Male	*	35	5940-2	5-Way Connector, Male	*
11	7996-1	1/4 x 16-14 GA QKS Term., Male	*	36	8942-1	5-Way Connector, Female	*
12	5996-8	6 GA Ring Lug (5/16)	*	37	7942-6	6-Way Connector, Male	*
13	5996-9	22-18 GA Ring Term., # 10	*	38	7942-7	6-Way Connector, Male	*
14	5996-10	16-14 GA Ring Term. (5/16)	*	39	7942-8	8-Way Connector, Male	*
15	5996-12	12-10 GA Ring Term. (5/16)	*	40	8942-2	8-Way Connector, Female	*
16	5996-13	16-14 GA Ring Term., # 10	*	41	8942-3	5-Way Connector, Male	*
17	5996-15	12-10 GA Ring Term. (1/2)	*	* Service Part Only			
18	5996-16	6 GA Ring Terminal (1/4)	*	NOTE: Not all Electrical Connectors are used with all assemblies.			
19	5996-17	16-14 GA Ring Term. (1/4)	*	NOTE: Refer to ELECTRICAL ASSEMBLY , Page 34 for locations of Wiring Harness and of all Electrical Wiring Service Parts.			
20	5996-20	12-10 GA Ring Term. (1/4)	*				
21	5996-21	12-10 GA Ring Term., # 10	*				
22	7942-4	Single Connector, Male	*				
23	8942	2-Way Connector, Male	*				
24	7942-1	2-Way Locking Connector, Female	*				

ELECTRICAL CONNECTORS

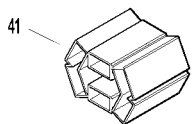
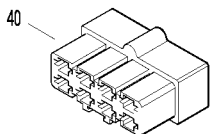
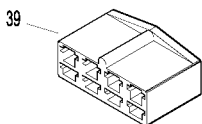
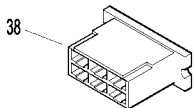
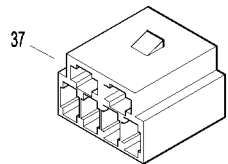
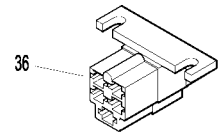
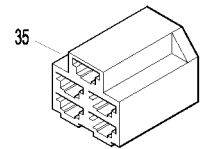
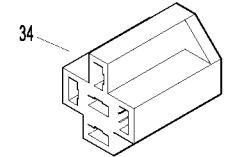
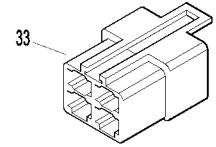
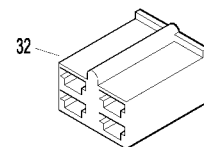
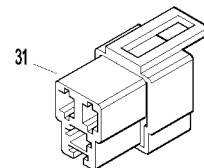
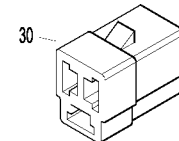
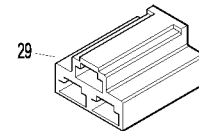
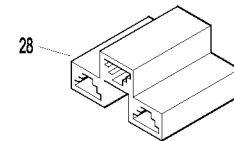
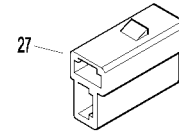
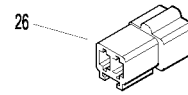
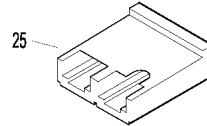
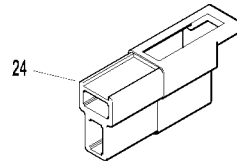
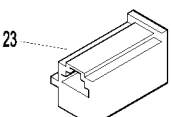
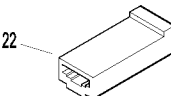
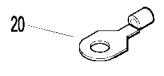
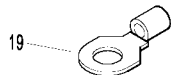
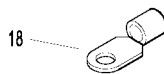
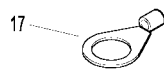
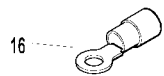
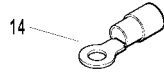
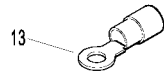
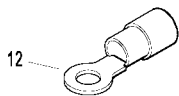
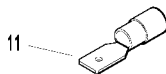
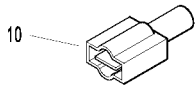
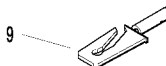
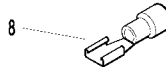
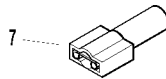
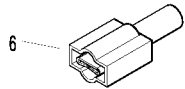
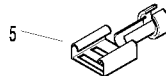
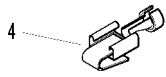
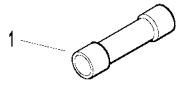

EFI BODY & ELECTRICAL ASSEMBLY

ITEM NO.	PART NO.	DESCRIPTION	NO. REQ'D	ITEM NO.	PART NO.	DESCRIPTION	NO. REQ'D
Body Assembly				Fasteners			
1	8100-10	Body Assembly/MTGHS 26 HP	1	F002		10-24 Keps Nut	4
				F025		10-24 x 3/8 PPHMS	2
				F085		3/16 Rivet Backup Washer	2
				F128		10-24 x 3/8 PTHMS	1
				F129		10-24 x 1/2 PTHMS	1
				F324		M8 x 1.25 x 12 Hex Bolt	1
Electrical Assembly							
2	NS	ECU Module	1				
3	NS	Fuse Holder	2				
4	6941-3	10 Amp Fuse	1				
5	6941	Relay Switch (30/40 Amp)	1				
6	5975-3	Cable Tie (#50 x 7")	2				
7	8940-25	ECU Cover, EFI	1				
8	8940-14	Wire Harness, EFI	1				
9	6941-1	20 Amp Fuse	1				
10	8940-10	Wire Harness, EFI Adapter	1				

EFI BODY & ELECTRICAL ASSEMBLY

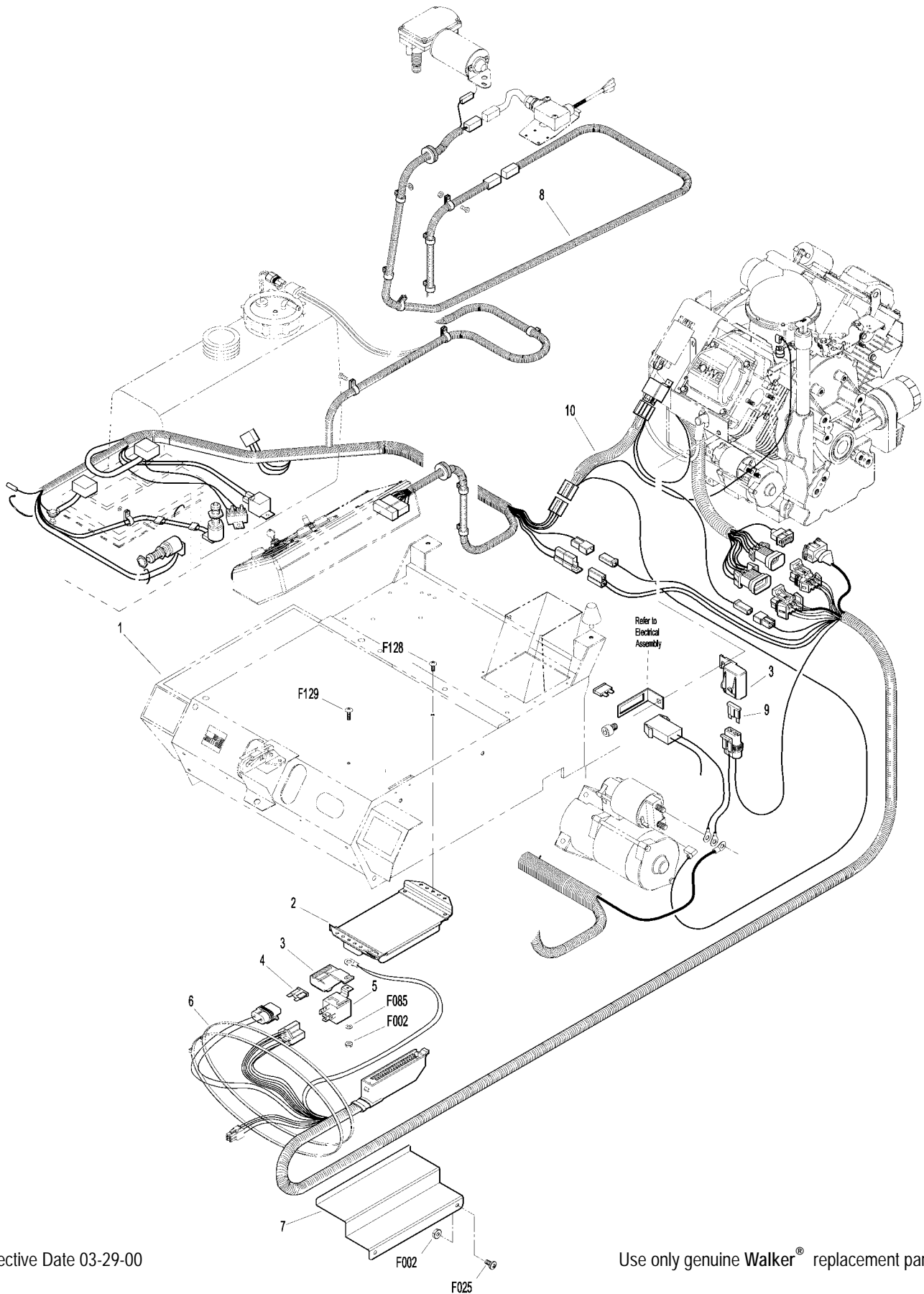

Effective Date 03-29-00

Use only genuine Walker® replacement parts.

EFI ENGINE FUEL & MUFFLER ASSEMBLY

ITEM NO.	PART NO.	DESCRIPTION	NO. REQ'D	ITEM NO.	PART NO.	DESCRIPTION	NO. REQ'D
Fuel Tank Assembly				10	NS	Engine, 26 HP EFI (Optional or Exchange)	1
1	8046-10	Tank, Fuel 4.3 Gal. Gas EFI	1	Exhaust Assembly			
2	NS	Ring, Retaining (Kohler# 24 141 08 - S)	1	11	NS	Sensor, Oxygen (Kohler# 24 418 05 - S) (Includes Item 11)	1
3	NS	Pickup Assembly, Fuel (Kohler# 24 381 07 - S)	1	12	NS	Washer, Oxygen	1
4	5975-3	Cable Tie (50# x 7")	1	13	8013-10	Muffler	1
5	NS	Line, Fuel Return (5/16) 40 PSI (Kohler# 24 326 51 - S)	1	14	8940-11	Wire, Oxygen Ground	1
6	NS	Filter, Fuel (Kohler# 24 050 03 - S)	1	Fasteners			
7	NS	Gasket (Kohler# 24 041 39 - S)	1	F184		Bolt, 1/4-20 x 1/2 Hex - SS	1
Engine Assembly				F185		Washer, 1/4 Internal Star Lock	1
8	NS	Clamp, Hose (Kohler 7840 x 2)	2	F324		Bolt, M8 x 1.25 x 12 Hex	1
9	8026-10	Hose, Air Cleaner (T) EFI	1				

EFI ENGINE FUEL & MUFFLER ASSEMBLY

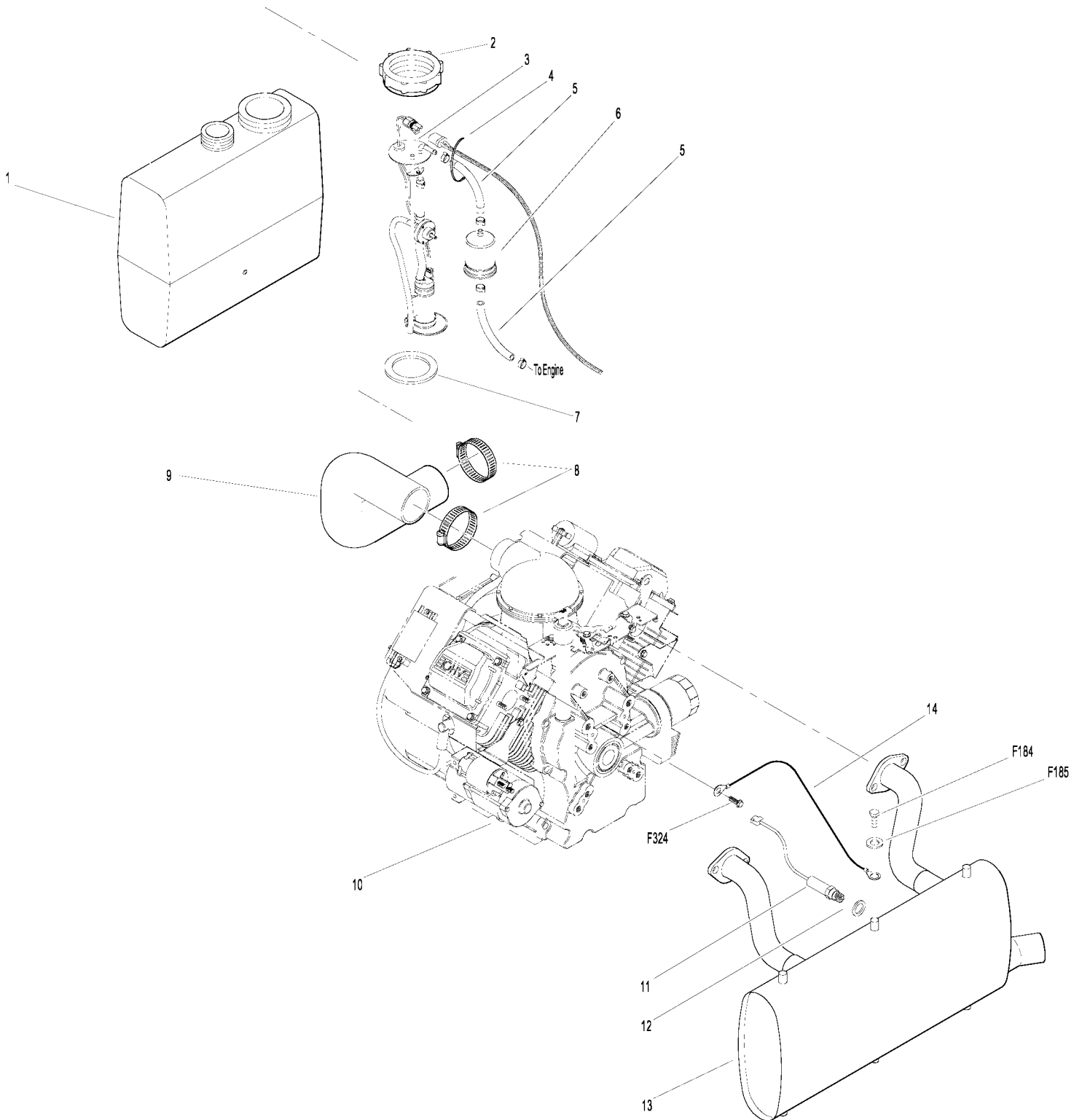

EFI INSTRUMENT PANEL ASSEMBLY

ITEM NO.	PART NO.	DESCRIPTION	NO. REQ'D	ITEM NO.	PART NO.	DESCRIPTION	NO. REQ'D
Instrument Panel Assembly				18	8945-2	Wire Harness, Instrument Panel	1
1	7307-2	Instrument Panel Cover (Optional)	*	19	7386	Panel Gasket	1
	8306-1	Instrument Panel Assembly EFI (Includes Items # 2, 3, 5-16, 19, 20, 25, F228, F250 & F251)	1	20	5995	Toggle Switch (Off-On)	1
2	7307	Panel Frame	1	21	7391	Panel Box Mount Plate	2
3	5995-2	Switch Boot (Fits P/N 5995)	1	22	8977	Grommet 1/8 x 7/8	1
4	7990	Hourmeter	1	23	7307-1	Shock Mount (1.0 OD x .25)	3
5	8997	Voltmeter Gauge	1	24	8385	Panel Box	1
6	8996-4	Red Indicator Lens	2	25	8536	Warning Horn	1
7	8996-3	Indicator Bulb (Replacement for P/N 8996-2)	**	26	7307-15	Foam Insert, Panel Box	1
8	8996-2	Red Indicator Light Assembly (Includes Items # 6 & 7)	2	Fasteners			
9	7854	Tip, Red	1	F004	1/4-20 Keps Nut		6
10	8960-15	Ignition Switch (with Keys) (Includes Item # 8)	1	F238	J Clip, Instrument Panel C15520-6A		8
11	8960-2	Ignition Key (1 Set)	**	F250	6-32 x 3/8 PPHMS		2
12	8996-6	Amber Indicator Lens	1	F251	6-32 Keps Nut		2
13	8996-10	Amber Indicator Light Assembly (Includes Items #7 & 12)	1	F349	Washer .835 ID, 1.122 OD, SS		1
14	8823-10	Decal, Instrument Panel	1	F228	#6 x 5/8 PPH SMS, SS		8
15	8820-15	Panel Faceplate	1	* May be ordered as an option. Contact your Walker dealer.			
16	5995-1	Wire Terminal Adapter	1	** Service Part Only			
17	5975-1	Cable Tie (18# x 3-3/4)	2	NOTE: Refer to ELECTRICAL CONNECTORS , Page 36 for identification of all Electrical Wiring Service Parts.			

EFI INSTRUMENT PANEL ASSEMBLY

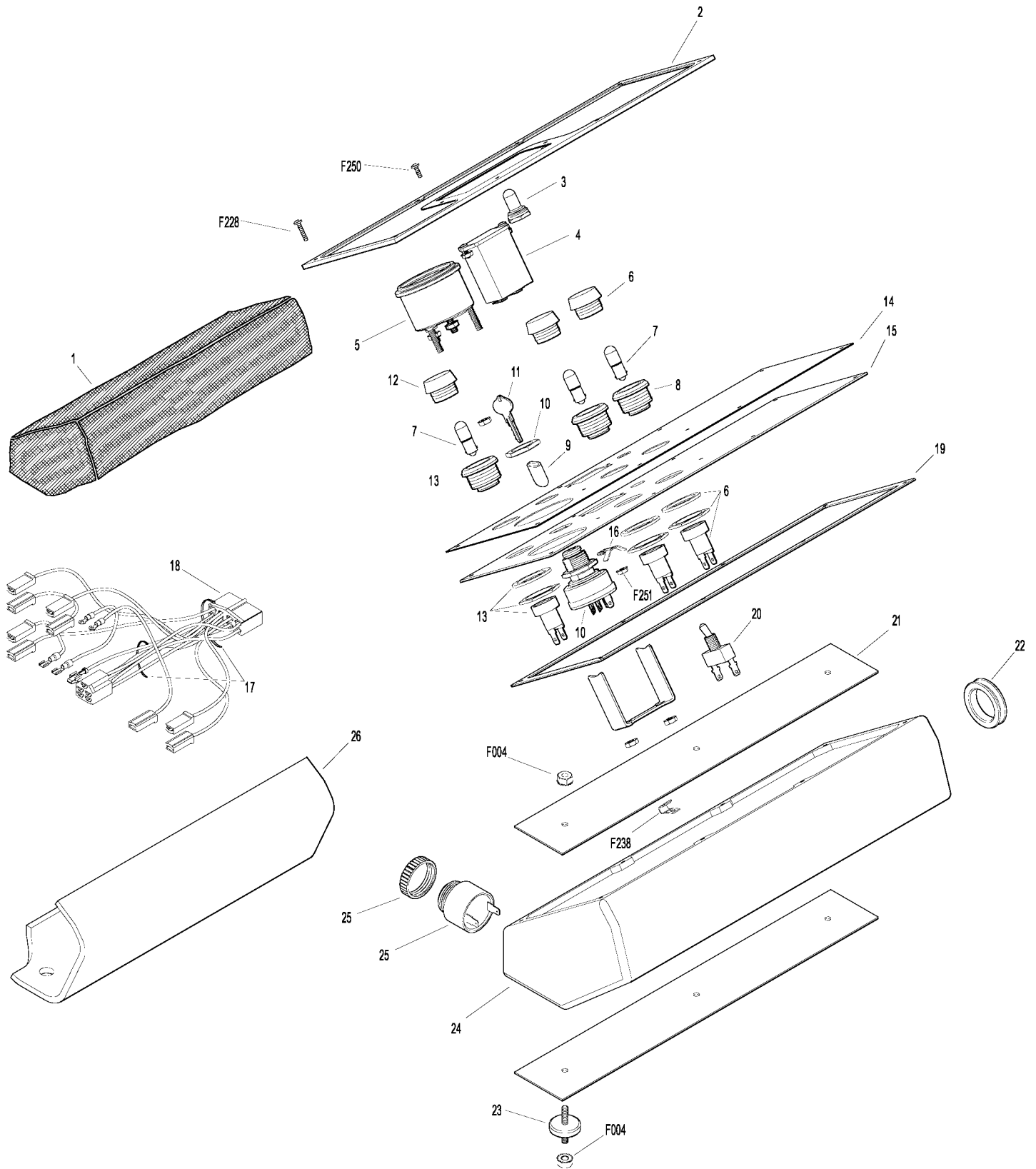

POWER DECK LIFT KIT

ITEM NO.	PART NO.	DESCRIPTION	NO. REQ'D	ITEM NO.	PART NO.	DESCRIPTION	NO. REQ'D	
Kit 8655 Power Deck Lift Option / Kit Includes Item numbers 1 thru 32, fasteners listed and instructions. May be ordered as a factory-installed option or as a kit for dealer installation. Contact your Walker dealer.				Fasteners				
1	8628	Linear Actuator, Deck	1	F002		10-24 Keps Nut	1	
2	8655-8	Clamp Bar	1	F004		1/4-20 Keps Nut	9	
3	7503-10	Actuator Drive Bushing	1	F009		5/16-18 Whiz Locknut	6	
4	8655-11	Bushing (5/8 OD x 5/16 x 1/16)	1	F025		10-24 x 3/8 PPHMS	1	
5	8655-10	Bushing (5/8 OD x 5/16 x 1/16)	1	F029		1/4-20 x 1/2 Hex Bolt	8	
6	8655-7	Arm, Deck Lift	1	F050		1/4 SAE Washer	1	
7	8655-9	Cable Pull	1	F061		1/4 Star Lock Washer	1	
8	8655-12	Bushing (3/4 OD x 1/4 ID x 3/4)	1	F068		1/8 x 1 Cotter Pin	1	
9	5977-1	Grommet (1/8 x 3/8)	1	F069		3/32 x 1/2 Cotter Pin	2	
10	8649	Wire Harness, Deck Lift	1	F093		5/16-18 x 1 Hex Bolt	2	
11	5975-5	Wire Clip, Self Mount	1	F111		1/8 x 3/4 Cotter Pin	1	
12	6623	Lift Control Switch	1	F134		AN960816L Washer	1	
13	5996-21	12-10 GA Ring Terminal (# 10)	*	F179		1/4-20 x 1 Hex Bolt	1	
14	8655-1	Cotterless Hitch Pin (5/8)	2	F316		5/16-18 x 1-3/4 Hex Bolt	2	
15	8627	Deck Bracket, Power Lift	2	F320		1/8 x 3/4 Split Spring Pin	*	
16	8655-6	Lift Chain	2	* Service Part Only				
17	8655-5	Cable Mount	2					
18	5996-20	12-10 GA Ring Terminal (1/4)	*					
19	8942-3	Five-Way Connector (M)	*					
20	5940-4	16-14 GA Spring-Loaded Terminal (F)	*					
21	8655-3	Cable LH (48")	1					
22	8655-2	Cable RH (38.5")	1					
23	8654	Decal, Deck Lift	1					
24	6623-1	Switch Boot	1					
25	6832	Cable Clamp (9/16 x 1/4)	1					
26	5832	Cable Clamp (1/2)	1					
27	8655-22	Base, Deck Lift	1					
28	8655-4	Clevis Pin (5/16 x 3/4)	2					
29	5975-3	Cable Tie (# 50 x 7)	3					
30	7942-1	Two-Way Locking Connector (F)	*					
31	5940-5	16-14 GA Spring-Loaded Terminal (M)	*					
32	7942-10	Two Way Locking Connector (M)	*					

Use only genuine **Walker®** replacement parts.

Effective Date 3/29/00

POWER DECK LIFT KIT

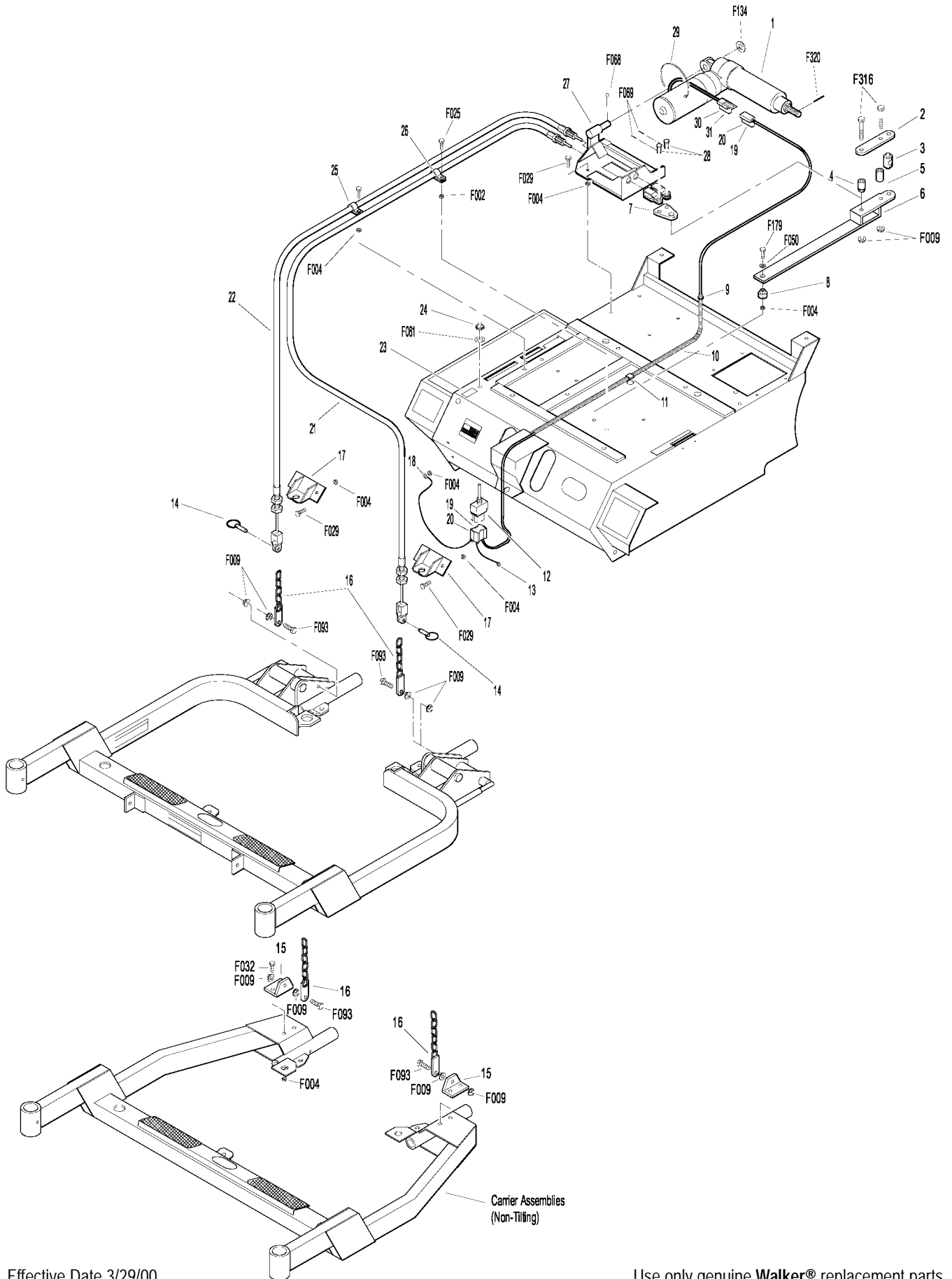

Effective Date 3/29/00

Use only genuine **Walker®** replacement parts.

ARMREST KIT / TOUCH-UP PAINT

ITEM NO.	PART NO.	DESCRIPTION	NO. REQ'D	ITEM NO.	PART NO.	DESCRIPTION	NO. REQ'D
Kit 5885 Armrest Option / Kit Includes item numbers 1 thru 5, fasteners listed and instructions. May be ordered as a factory-installed option or as a kit for dealer installation. Contact your Walker dealer.				7	5871	Touch-Up Paint, Yellow (1 qt.)	
			1	8	5871-1	Touch-Up Paint, Yellow (1 gal.)	
			1	9	5867	Touch-Up Paint, Grey (12 oz. Aerosol)	
			1	10	5873	Touch-Up Paint, Grey (1 qt.)	
			1	11	5873-1	Touch-Up Paint, Grey (1 gal.)	
1	5886-1	Armrest, RH	1	Fasteners			
2	5886-3	Cover Plate, RH	1		F305	1/4-20 x 3/8 SH Cap Screw	2
3	5887	Mounting Bracket	1		F306	3/8-16 x 3/4 Hex Bolt	4
4	5886-4	Cover Plate, LH	1		F307	# 10 x 5/8 PPHST Screw	2
5	5886-2	Armrest, LH	1		F308	1-1/4 x 1-5/8 Wave Spring Washer	2
	5888	Armrest Hardware Kit	*				
	(Includes Items # F305, F306, F307 & F308)						
Walker Touch-Up Paint				* Service Part Only			
6	5866	Touch-Up Paint, Yellow (12 oz. Aerosol)					

ARMREST KIT / TOUCH-UP PAINT

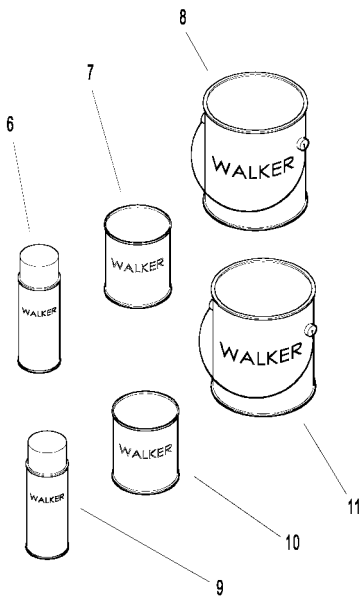
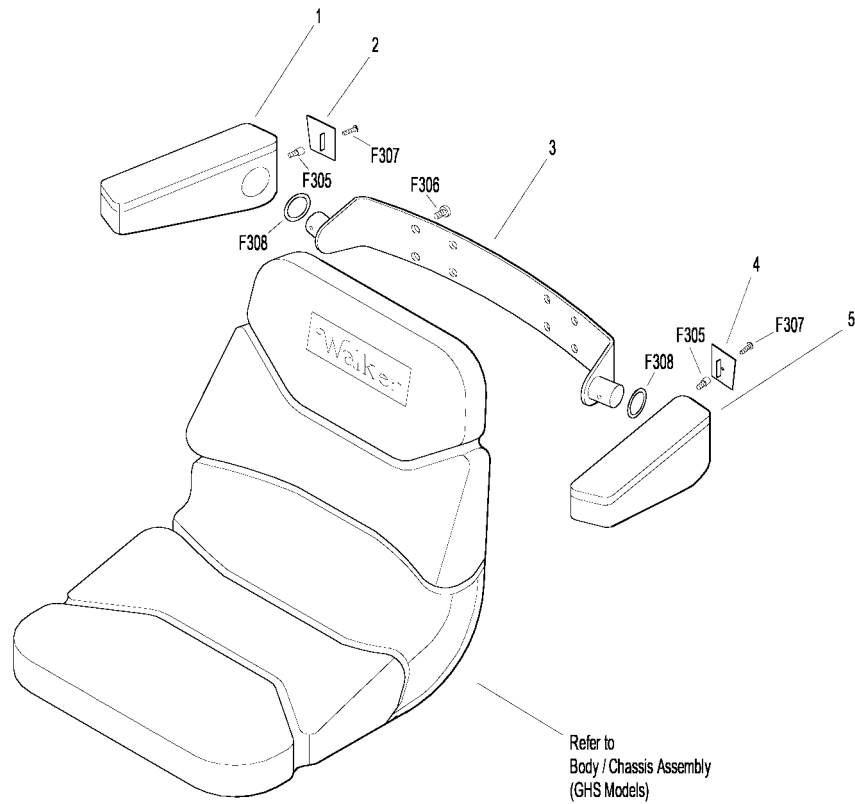

COMFORT SEAT / ARMREST KIT

ITEM NO.	PART NO.	DESCRIPTION	NO. REQ'D	ITEM NO.	PART NO.	DESCRIPTION	NO. REQ'D
Comfort Seat				Fasteners			
1	6103-5	Comfort Seat	1*		F009	5/16 - 18 Whiz Locknut	**
2	7203	Seat Spring Plate	**		F227	3/8-1-1/4 x 1/8 Plastic Washer	**
3	7223	Compression Spring (1/2 x 1)	**				
4	7845	Rubber Bumper (1.375 OD x .63)	**	*		May be ordered as a factory-installed option	
5	7846	Rubber Washer (3/8ID x 1-1/4 OD x 1/8)	**	**		Existing part	
6	7204	Shoulder Bolt, Seat Mount	**				
7	7440-5	Shock Mount (1.25 D x .75)	**				

Kit 6103-15 Armrest Option / Kit

Includes item numbers 8, 9 and instructions. Item #8 is the **Right** side armrest only. Item #9 is the **Left** side armrest only. Sold only as a complete set and can be ordered together in a kit or as a factory-installed option. Contact your Walker dealer.

COMFORT SEAT / ARMREST KIT

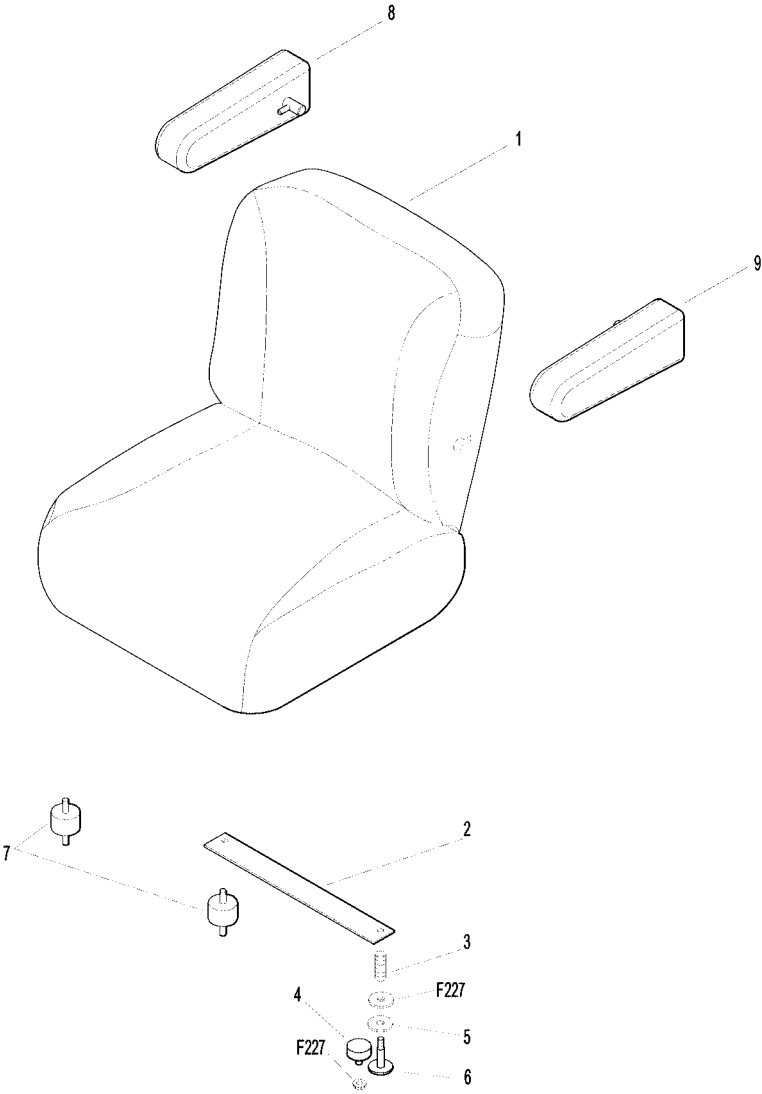

SUSPENSION SEAT KIT

ITEM NO.	PART NO.	DESCRIPTION	NO. REQ'D	ITEM NO.	PART NO.	DESCRIPTION	NO. REQ'D
Kit 6103-10 Suspension Seat Option / Kit Includes item numbers 1 thru 10, fasteners listed and instructions. May be ordered as a factory-installed option or as a kit for dealer installation. Contact your Walker dealer.				Fasteners			
1	6103-11	Suspension Seat	1		F009	5/16-18 Whiz Locknut	4
2	5941	Safety Switch (Includes Item # 3)	2		F168	5/16 Split Lock Washer	4
3	5941-1	Switch Boot	*		F357	M8 x 16 Hex Bolt	2
4	6103-34	Seat Mount Plate, RH	1		F358	M8 x 25 Hex Bolt	2
5	6103-33	Seat Mount Plate, LH	1				
6	7440-5	Shock Mount (1.25 x 0.75)	2				
7	5977-5	Grommet (5/8)	2				
8	5975-3	Cable Tie (50# x7")	2				
9	5975-1	Cable Tie (18# x 3-3/4)	1				
10	6103-12	Wire Harness, Suspension Seat (Connector plug sent loose)	1				
				*		Service Part Only	

SUSPENSION SEAT KIT

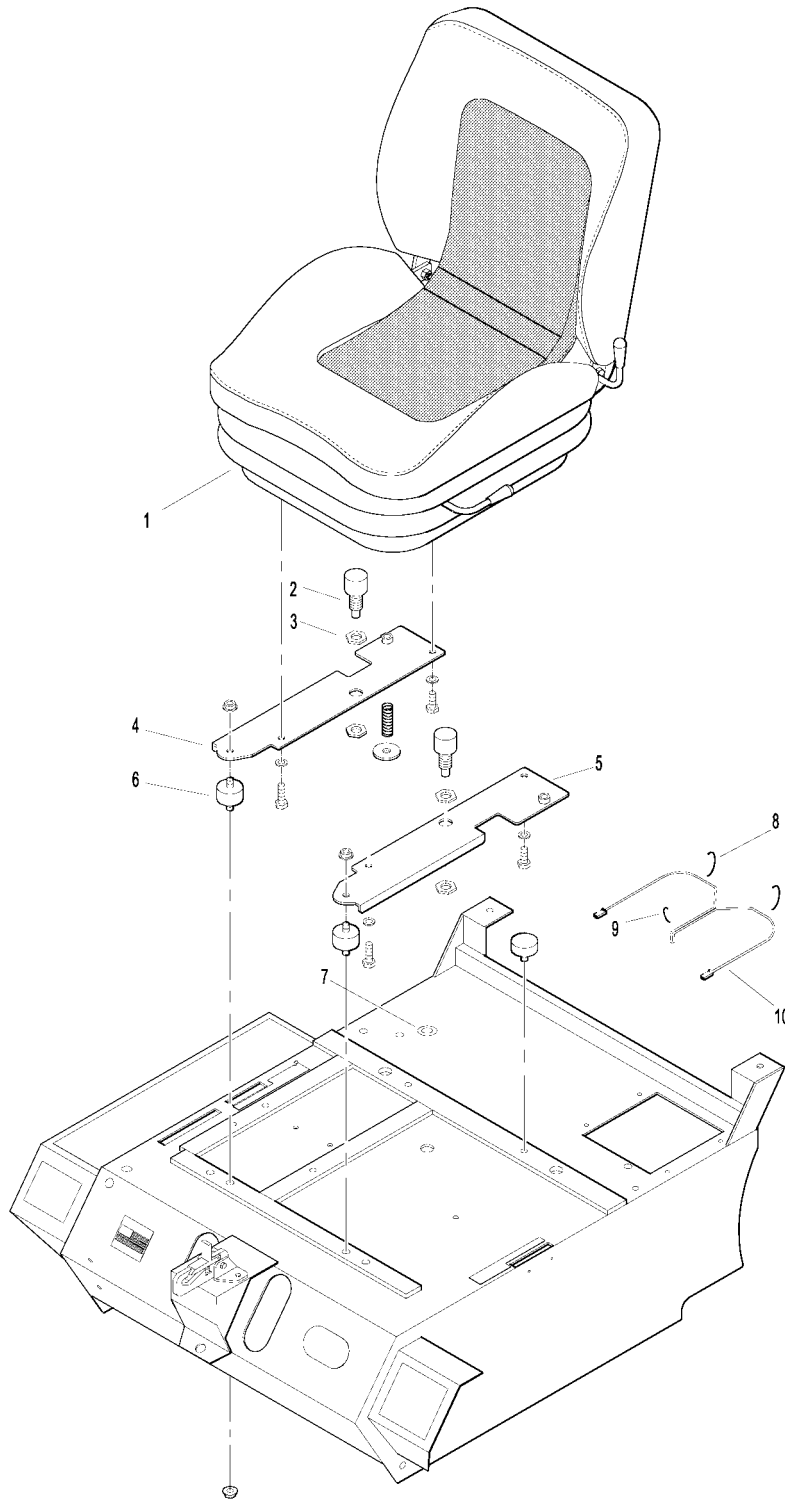

LIGHT KIT

ITEM NO.	PART NO.	DESCRIPTION	NO. REQ'D	ITEM NO.	PART NO.	DESCRIPTION	NO. REQ'D
Kit 7989-1 Light Option / Kit Includes item numbers 1 thru 8, fasteners listed and instructions. May be ordered as a factory-installed option or as a kit for dealer installation. Contact your Walker dealer.				Fasteners			
1	5989-2	Light Assembly (Includes Sealed Beam Lamp)	2		F009	5/16-18 Whiz Locknut	2
	5989-6	Sealed Beam Lamp (Fits 5989-2)	*		F091	5/16-18 x 5/8 Hex Bolt	2
2	5996-15	12-10 Gauge Ring Terminal (1/2)	2		F134	AN960816L Washer	2
3	7834-1	Half U-Wire Clip	4	* Service Part Only			
4	7993	Mount Bracket, Lights (Includes Items # 3 & 5)	1	NOTE: Upon installation of kit, Item # 6 replaces P/N 5989-4 (Dome Plug, 3/8) and Item # F091 replaces P/N 5989-3 (Dome Plug, 5/16). Dome Plugs are not shown here. Refer to BODY / CHASSIS ASSEMBLY (GHS MODELS) , Page 4.			
5	7995-3	Power Lead Wire Assembly (Lights)	1	NOTE: Refer to ELECTRICAL CONNECTORS , Page 36 for identification of all Electrical Wiring Service Parts.			
6	5977-1	Grommet (1/8 x 3/8)	2				
7	5975-5	Wire Clip, Self-Mount	3				
8	5975-1	Cable Tie (18# x 3-3/4)	1				

LIGHT KIT

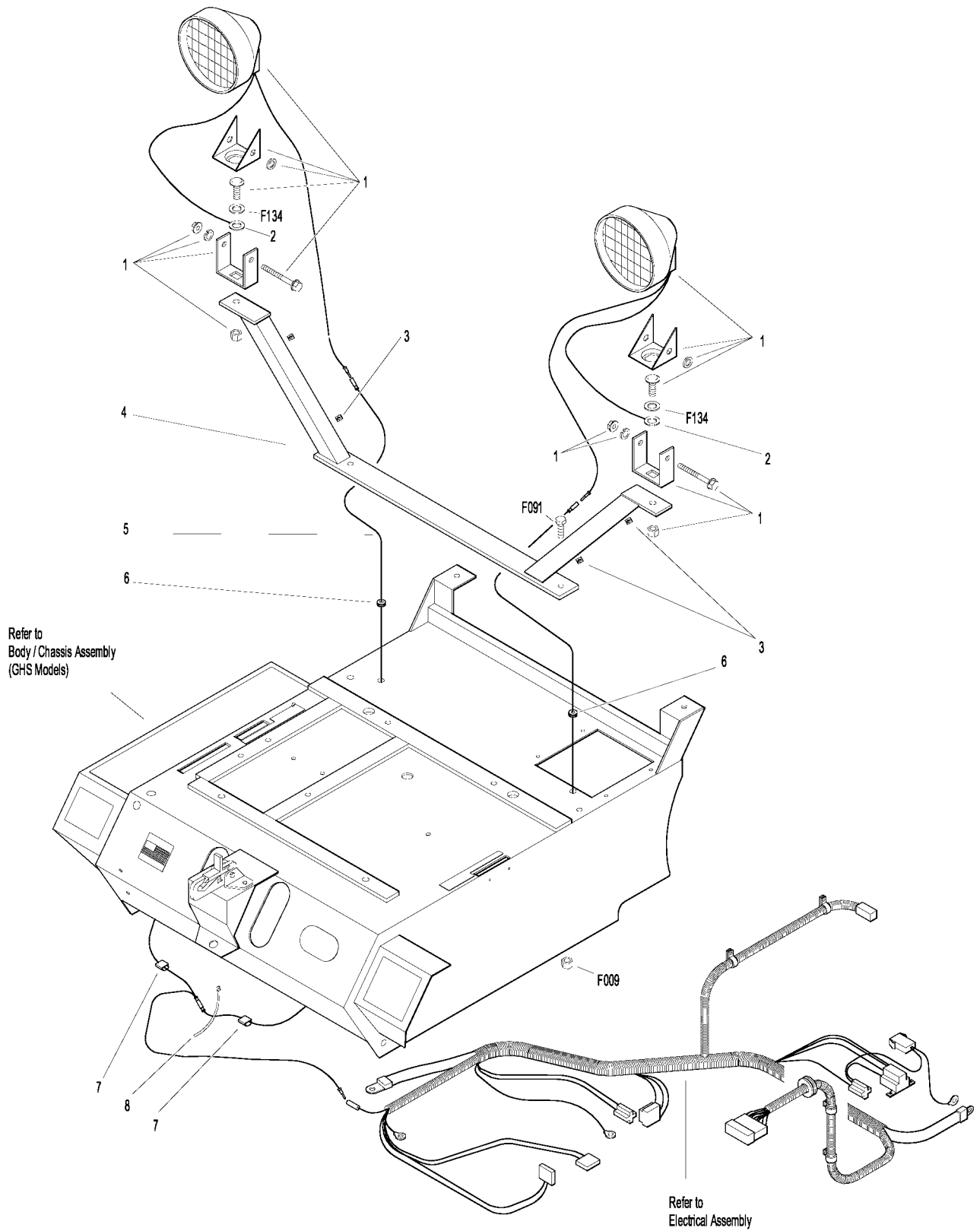

COLD START KIT / SPEED UP KIT

ITEM NO.	PART NO.	DESCRIPTION	NO. REQ'D	ITEM NO.	PART NO.	DESCRIPTION	NO. REQ'D
Kit 8638 Cold Start Option / Kit Includes item numbers 1 thru 3, fasteners F004, F029, and instructions.				Fasteners			
1	7406-1	Handle Grip (Red)	1		F004	1/4-20 Keps Nut	2
2	5830	Grease Fitting	1		F029	1/4-20 x 1/2 Hex Bolt	2
3	8638-1	Idler Release (Includes Items # 1 & 2)	1		F171	5/16-18 x 3/8 Set Screw	*
Kit 8246 Speed-Up Option / Kit Includes item numbers 4, 5, and instructions.				* Service Part Only			
4	5224	Extension Spring (1 x 4)	1				
5	7240-2	Jackshaft Drive Pulley (3V2-3/4) (Includes Items # F171)	1				

Both kits may be ordered as a factory-installed option or as a kit for dealer installation. Contact your Walker dealer.

COLD START KIT / SPEED UP KIT

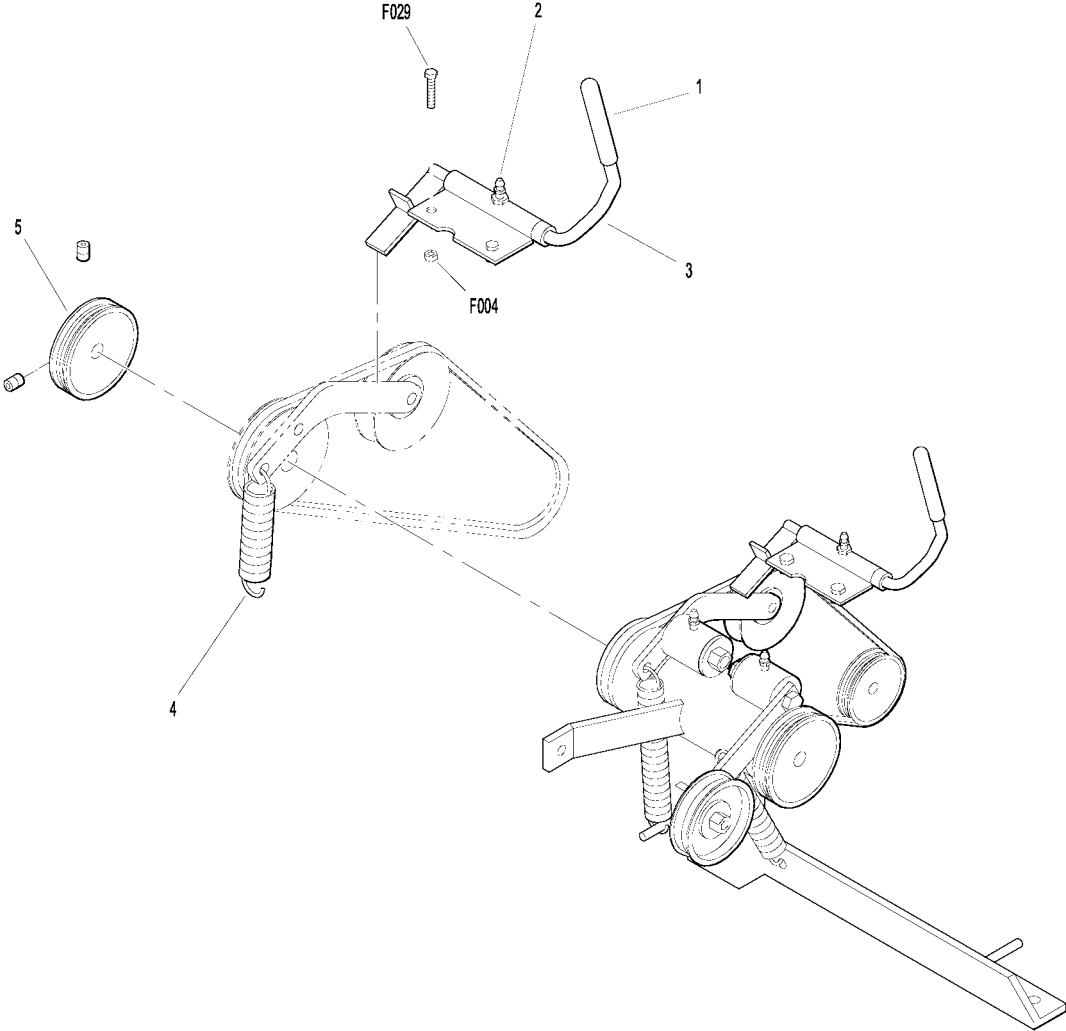

POWER DUMP KIT (7.0 BUSHEL GHS MODELS ONLY)

ITEM NO.	PART NO.	DESCRIPTION	NO. REQ'D	ITEM NO.	PART NO.	DESCRIPTION	NO. REQ'D	
Kit 7620 Power Dump Option / Kit (7.0 Models Only) Includes item numbers 1 thru 29, fasteners listed and instructions. May be ordered as a factory-installed option or as a kit for dealer installation. Contact your Walker dealer. Not to be used with optional Dump Bag Kits.				Fasteners				
1	7620-3	Door Pivot Bushing	2	F002		10-24 Keps Nut	4	
2	7612-2	Door Actuator Arm, RH	1	F003		1/4-28 Hex Nut	4	
3	7612-1	Door Actuator Arm, LH	1	F004		1/4-20 Keps Nut	8	
4	7610-5	Spring	1	F009		5/16-18 Whiz Locknut	3	
5	7523-2	Clevis Pin (1/4 x 5/8)	2	F012		3/8-16 Keps Nut	3	
6	7623	7.0 Power Dump Cable Assembly	2	F028		10-24 x 3/4 PPHMS	4	
7	5975-7	Cable Tie (50# x 11")	1	F029		1/4-20 x 1/2 Hex Bolt	4	
8	7621	Linear Actuator	1	F032		1/4-20 x 3/4 Hex Bolt	1	
9	5552	Ball Joint (1/4-28)	2	F039		3/8-16 x 1-1/4 Hex Bolt	2	
10	7628	Channel Angle, RH	1	F049		5/16 SAE Washer	2	
11	7620-9	Roller Wheel	2	F050		1/4 SAE Washer	2	
12	7629	Channel Angle, LH	1	F068		1/8 x 1 Cotter Pin	2	
13	5830	Grease Fitting	3	F069		3/32 x 1/2 Cotter Pin	2*	
14	7626-0	Actuator Mount	1	F079		A/A66D Aluminum Pop Rivet	1	
15	7624-1	Roller Bearing Bolt	1	F085		3/16 Rivet Backup Washer	4	
16	5832	Cable Clamp (1/2)	1	F093		5/16-18 x 1 Hex Bolt	2	
17	7627	Front Actuator Mount	1	F104		1/4-20 x 3/4 PFH Bolt	3	
18	7624	Sealed Needle Bearing	1	F111		1/8 x 3/4 Cotter Pin	1*	
19	7630-3	Ram Pivot and Spacer	1	F128		10-24 x 3/8 PTHMS	2	
20	7625	Fork	1	F134		AN960816L Washer	4	
21	5975-1	Cable Tie (18# x 3-3/4)	1	F249		M10 Split Lock Washer	2	
22	5975-3	Cable Tie (50# x 7")	5	F266		1/2 x 2-3/4 Shoulder Bolt	1	
23	7622	Wire Harness	1	F267		1/2 x 1 x 1/16 Washer	4	
24	6623	Lift Control Switch	1	F269		10-32 x 5/8 PTHMS	4	
25	6623-1	Switch Boot	1	F270		10-32 Cap Nut	4	
26	7633	Decal, Power Dump Switch	1					
27	7620-12	Cable Rod Guide	2					
28	7620-6	Cable Guide	2					
29	7613	Door Actuator	2					

* Reuse Existing Parts from 7.0 Bushel Catcher Assembly on units with Serial Number 94-16484 and later. Earlier Models require installation of Dump Plate Kit 7611.

NOTE: Two F009 Fasteners are reused from the Rear Gas Spring Assembly. Refer to **REAR BODY ASSEMBLY (GHS MODELS)**, Page 6.

NOTE: Refer to **ELECTRICAL CONNECTORS**, Page 36 for identification of all Electrical Wiring Service Parts.

POWER DUMP KIT (7.0 BUSHEL GHS MODELS ONLY)

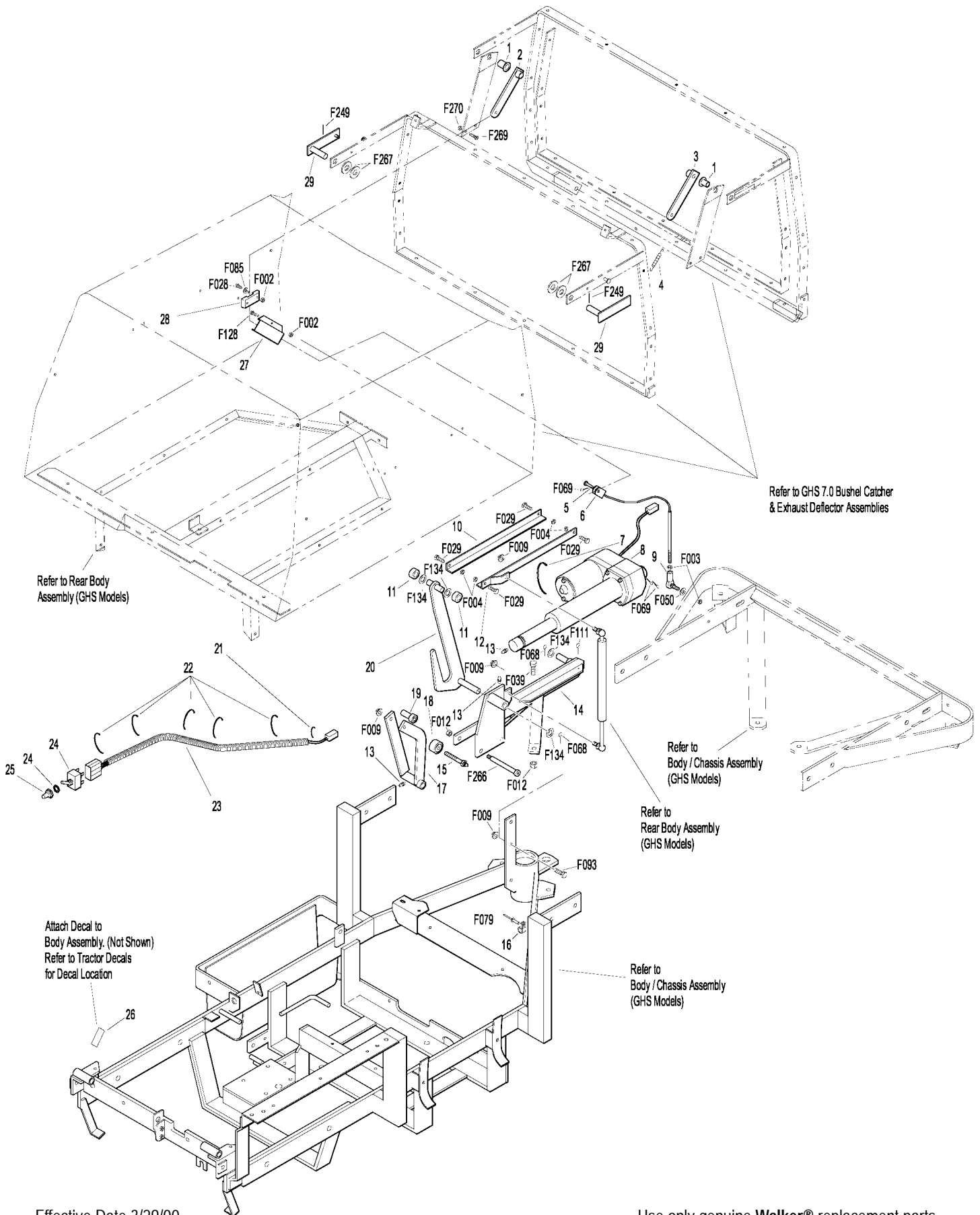

Effective Date 3/29/00

Use only genuine **Walker®** replacement parts.

POWER DUMP KIT (9.5 BUSHEL GHS MODELS ONLY)

ITEM NO.	PART NO.	DESCRIPTION	NO. REQ'D	ITEM NO.	PART NO.	DESCRIPTION	NO. REQ'D
Kit 8620 Power Dump Option / Kit (9.5 Models Only) Includes item numbers 1 thru 29, fasteners listed and instructions. May be ordered as a factory-installed option or as a kit for dealer installation. Contact your Walker dealer.				Fasteners			
1	7620-3	Door Pivot Bushing	2	F002		10-24 Keps Nut	6
2	7612-2	Door Actuator Arm, RH	1	F003		1/4-28 Hex Nut	4
3	7612-1	Door Actuator Arm, LH	1	F004		1/4-20 Keps Nut	8
4	7610-5	Spring	1	F009		5/16-18 Whiz Locknut	3
5	7523	Clevis Pin (1/4 x 5/8)	2	F012		3/8-16 Keps Nut	3
6	7623-2	9.5 Power Dump Cable Assembly	2	F028		10-24 x 3/4 PPHMS	4
7	5975-7	Cable Tie (50# x 11")	1	F029		1/4-20 x 1/2 Hex Bolt	4
8	7721	Linear Actuator	1	F032		1/4-20 x 3/4 Hex Bolt	1
9	5552	Ball Joint (1/4-28)	2	F039		3/8-16 x 1-1/4 Hex Bolt	2
10	8620-5	Guard, 9.5 P.D. Motor	1	F049		5/16 SAE Washer	2
11	7628	Channel Angle, RH	1	F050		1/4 SAE Washer	2
12	7620-9	Roller Wheel	2	F068		1/8 x 1 Cotter Pin	2
13	7629	Channel Angle, LH	1	F069		3/32 x 1/2 Cotter Pin	2
14	5830	Grease Fitting	3	F079		A/A66D Aluminum Pop Rivet	1
15	7636-1	Actuator Mount	1	F085		3/16 Rivet Backup Washer	4
16	7624-1	Roller Bearing Bolt	1	F093		5/16-18 x 1 Hex Bolt	2
17	5832	Cable Clamp (1/2)	1	F104		1/4-20 x 3/4 PFH Bolt	3
18	7627	Front Actuator Mount	1	F134		AN960816L Washer	4
19	7624	Sealed Needle Bearing	1	F266		1/2 x 2-3/4 Shoulder Bolt	1
20	7630-3	Ram Pivot and Spacer	1	F267		1/2 x 1 x 1/16 Washer	4
21	7625	Fork	1	F269		10-32 x 5/8 PTHMS	4
22	5975-1	Cable Tie (18# x 3-3/4)	1	F270		10-32 Cap Nut	4
23	5975-3	Cable Tie (50# x 7")	5	F317		3/16 x 1 Split Spring Pin	2
24	7622	Wire Harness	1	F337		1/4 - 20 x 5/8 Self Tap Bolt	2
25	6623	Lift Control Switch	1				
26	6623-1	Switch Boot	1				
27	7633	Decal, Power Dump Switch	1				
28	7620-6	Cable Rod Guide	2				
29	7613	Door Actuator	2				

NOTE: Two F009 Fasteners are reused from the Rear Gas Spring Assembly. Refer to **REAR BODY ASSEMBLY (GHS MODELS)**, Page 6.

NOTE: Refer to **ELECTRICAL CONNECTORS**, Page 36 for identification of all Electrical Wiring Service Parts.

NO CATCH DEFLECTOR KIT (7.0 BUSHEL & 9.5 BUSHEL)

ITEM NO.	PART NO.	DESCRIPTION	NO. REQ'D	ITEM NO.	PART NO.	DESCRIPTION	NO. REQ'D
Kit 7500 (7.0 Bushel) No Catch Deflector Option / Kit Includes item numbers 1 (7500-1) thru 5, fasteners listed and instructions.				Fasteners			
				F002		10-24 Keps Nut	4
				F030		1/4-20 x 1/2 PPH Bolt	1
				F128		10-24 x 3/8 PTHMS	4
				F146		1/4-20 Jam Nut	1
				F333		1/4-20 x 3/4 PTHMS	1
Kit 8500 (9.5 Bushel) No Catch Deflector Option / Kit Includes item numbers 1 (8500-1) thru 5, fasteners listed and instructions.							
Both kits may be ordered as a factory-installed option or as a kit for dealer installation. Contact your Walker dealer.							
1	7500-1	Deflector Assembly, (7.0)	1				
	8500-1	Deflector Assembly (9.5)	1				
2	8500-5	Side Bracket	2				
3	8787-2	Deflector Knob	1				
4	8500-6	Spacer Lug	1				
5	8500-8	Decal, No Catch Deflector	1				

7500 (7.0 BUSHEL) & 8500 (9.5 BUSHEL) NO CATCH DEFLECTOR KIT

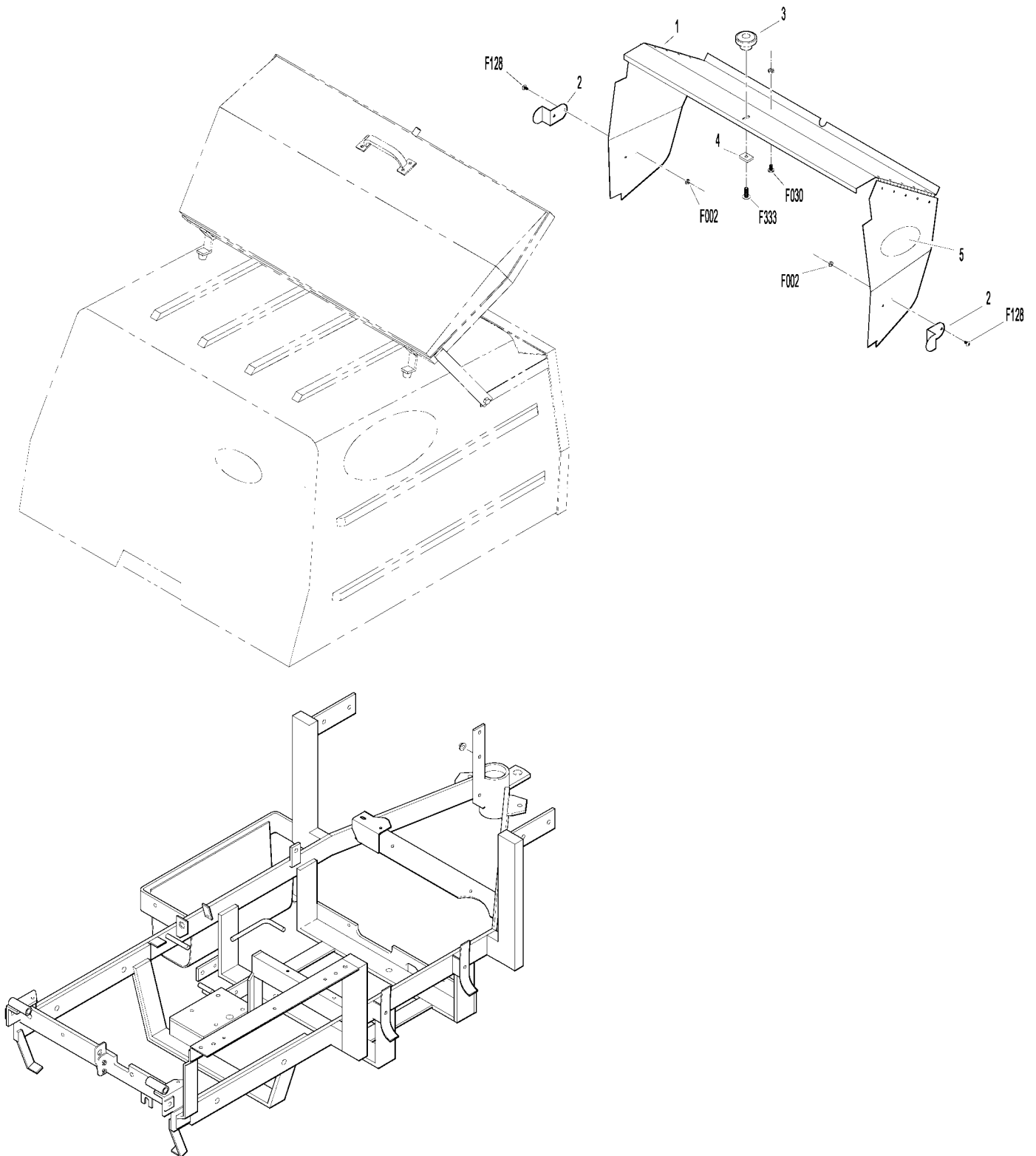

TAIL WEIGHT KIT

ITEM NO.	PART NO.	DESCRIPTION	NO. REQ'D	ITEM NO.	PART NO.	DESCRIPTION	NO. REQ'D
Kit 7647 Tail Wheel Option / Kit Includes item numbers 1, 2, F012, F039, and instructions. May be ordered as a factory-installed option or as a kit for dealer installation. Contact your Walker dealer.				Fasteners			
1	7637-1	Tractor Tail Weight	1	F012		3/8-16 Keps Nut	4
2	7647-9	Tail Weight Strap	2	F039		3/8-16 x 1-1/4 Hex Bolt	6
3	7647-5	Tail Weight Plate, 10-lb	*	F175		1/2 Split Lock Washer	2**
				F285		1/2-13 x 1-1/2 Hex Bolt	2**
				*		Optional	
				**		Use with optional 10-lb plate.	

TAIL WEIGHT KIT

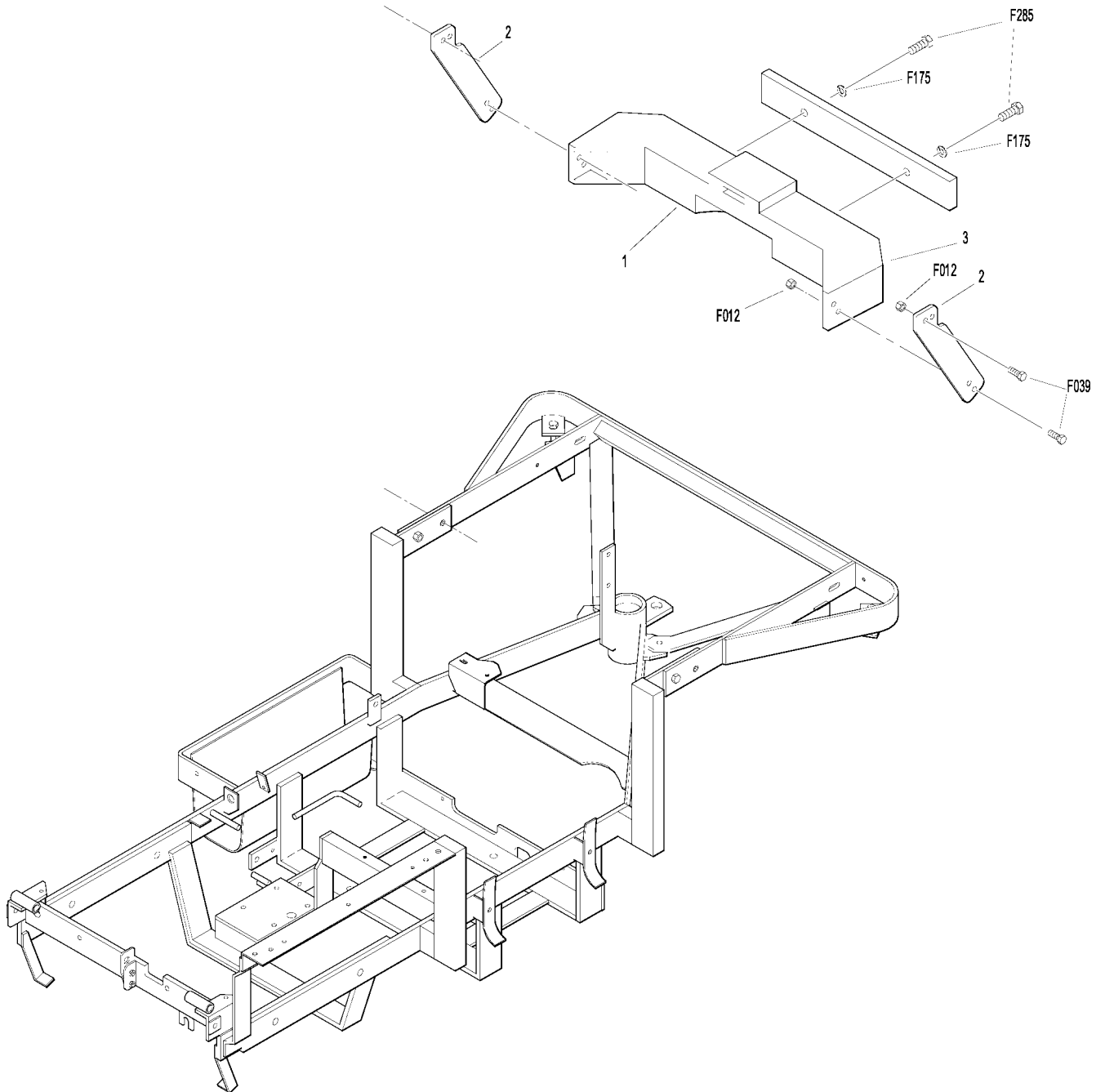

TAIL WHEEL LOCK KIT

ITEM NO.	PART NO.	DESCRIPTION	NO. REQ'D
Kit	8540	Tail Wheel Lock Option / Kit	
Includes item numbers 1 thru 32, fasteners listed & instructions. May be ordered as a factory-installed option or as a kit for dealer installation. Contact your Walker dealer.			
1	5995-2	Switch Boot	1
2	8547	Switch Mount	1
3	8555	Decal, Tail Lock Switch	1
4	5995	Toggle Switch (Off-On)	1
5	7942-4	Single Connector, Male	2*
6	5940-4	16-14 GA Spg. Loaded Term., Female	5*
7	5977-2	Grommet, Cut (1/8 x 3/8)	1
8	5975-3	Cable Tie (50# x 7")	4
9	8550	Wire Harness	1
10	5975-1	Cable Tie (18# x 3-3/4)	3
11	8553	Splice Tap (18-14 GA)	1
12	8543	Solenoid Mount	1
13	5830-3	Grease Fitting (45 Degree)	1
14	8551	Ground Wire	1
15	8546	Solenoid, Control Module	1
16	5996	1/4 16-14 GA QKS Term., Female	5*
17	8552	Connector Plug & Wire Assy	1
18	8544	Clevis, Wheel Lockout	1
19	5555-1	Pivot Bearing	2*
	8545-1	Pivot Bearing Assembly (Includes Items # 15, 16, F179, F350)	
20	8544-1	Bearing Spacer	1*
21	8542	Locking Tail Wheel Fork	1
22	8944	3 Way Locking Connector, Male	1*
23	8944-1	3 Way Locking Connector, Female	1*
24	5940-5	16-14 GA Spg. Loaded Term., Male	1*
25	5996-13	16-14 GA Ring Term., # 10	1*
26	7929	Actuating Solenoid	1
27	8549	Sleeve, Delrin	1
28	8541	Plunger Rod	1
	8554	Solenoid Mount Assembly (Includes Items # 7, 8, 11-20, 22-27, F002, F003, F004, F029, F050, F179, F190, F198, F298 & F299)	*

ITEM NO.	PART NO.	DESCRIPTION	NO. REQ'D
----------	----------	-------------	-----------

The following parts are included in kit but used only on MD MODELS:

29	8548	Spacer Block	1
30	7941-4	Circuit Breaker (25 Amp)	1
31	7047-5	Mount Plate	1
32	5832	Cable Clamp (1/2)	2
	F002	10-24 Keps Nut	2
	F004	1/4-20 Keps Nut	2
	F026	10-24 x 1/2 PPHMS	2
	F104	1/4-20 x 3/4 PFH Bolt	2
	F187	1/4-20 x 1-1/2 Hex Bolt	2

Fasteners

	F002	10-24 Keps Nut	4
	F003	1/4-28 Hex Nut	1
	F004	1/4-20 Keps Nut	3
	F012	3/8-16 Keps Nut	2
	F026	10-24 x 1/2 PPHMS	2
	F029	1/4-20 x 1/2 Hex Bolt	2
	F038	3/8-16 x 1 Hex Bolt	2
	F050	1/4 SAE Washer	2
	F134	AN960816L Washer	1
	F179	1/4-20 x 1 Hex Bolt	2
	F190	# 10 Internal Star Lock Washer	1
	F198	.250 x .625 x .040 Washer, SS	1
	F298	3/8-24 Jam Nut	1
	F299	10-24 x 1 PPHMS	2
	F300	1.015 x 1.500 x .031 Washer	1
	F350	1/4-20 LP Nylock	1

* Service Part Only

NOTE: Refer to **ELECTRICAL CONNECTORS**, Page 36 for identification of all Electrical Wiring Service Parts.

TAIL WHEEL LOCK KIT

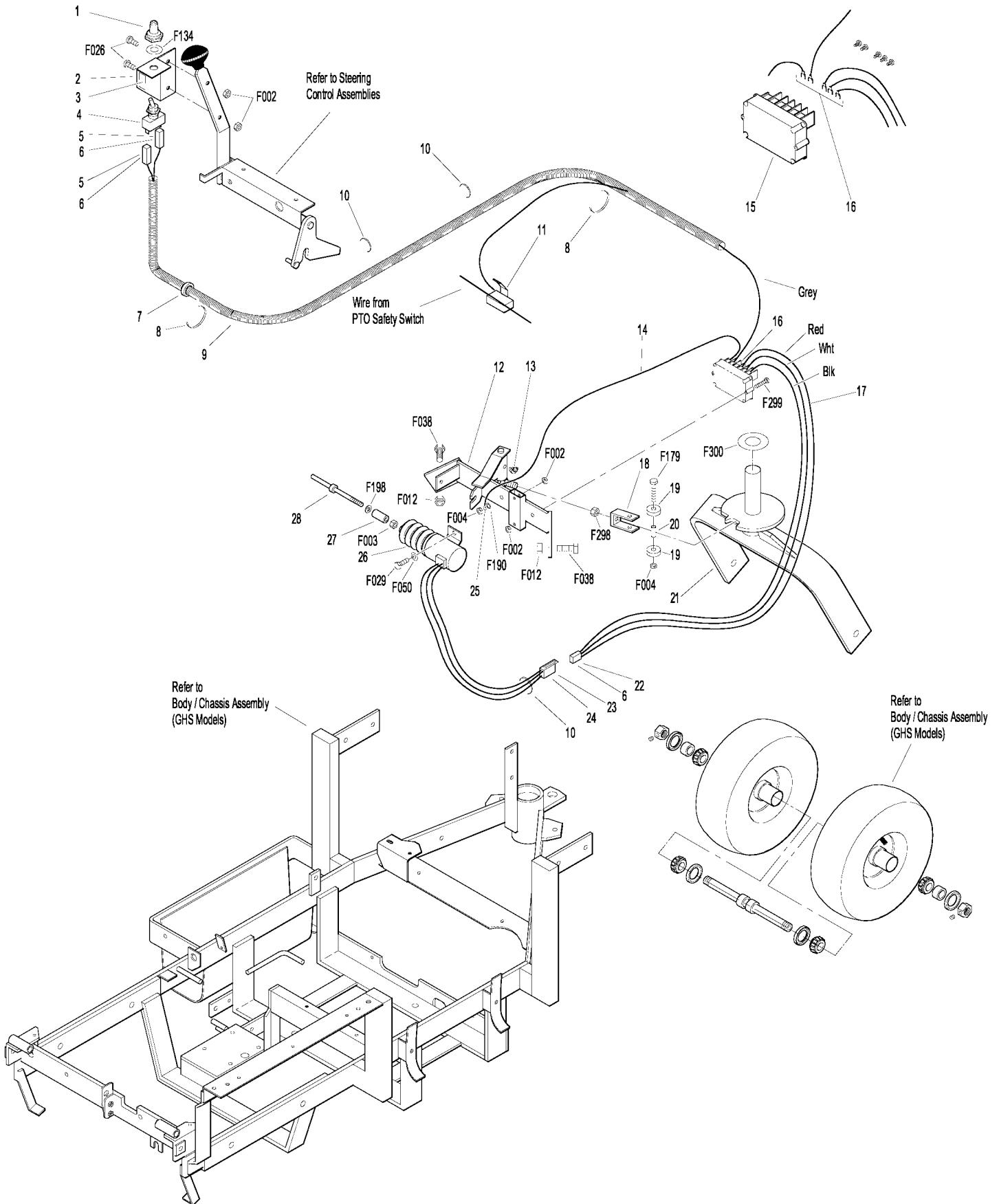

Effective Date 3/29/00

Use only genuine **Walker®** replacement parts.

WIDE TAIL WHEEL / ALL-TERRAIN TIRE KIT & TIRE CHAIN SET

ITEM NO.	PART NO.	DESCRIPTION	NO. REQ'D
----------	----------	-------------	-----------

Kit 8049 Wide Tail Wheel Option / Kit
Includes item numbers 1, 2, and instructions. May be ordered as a factory-installed option or as a kit for dealer installation. Contact your Walker dealer.

1	8037-1	Seal, Tail Wheel	2
2	8045	Wide Tail Wheel & Tire Assembly (13 x 8.00-6)	1
	8045-1	Tire Only (13 x 8.00-6)	*
	8047	Wheel & Hub Only (6 x 7)	*

Kit 8072 All-Terrain Tire Option / Kit
Includes item numbers 3 thru 5, and instructions. May be ordered as a factory-installed option, or as a kit for dealer installation. Contact your Walker dealer.

3	8071	All-Terrain Wheel & Tire, LH (18 x 11.00-10)	1
4	8070-31	Wheel Spacer Plate (1/2)	2
5	8070	All-Terrain Wheel & Tire, RH (18 x 11.00-10)	1
	8070-1	AT Tire Only (18 x 11.00-10)	*
	8070-2	AT Wheel Only (10 x 8.5)	*

ITEM NO.	PART NO.	DESCRIPTION	NO. REQ'D
----------	----------	-------------	-----------

Optional Tire Chain Set
Includes item numbers 4 and 6.

6	5675-3	Tire Chain Set (18 x 9.50-8) (For use with Wide Wheel and Tire Assy)	1
*		Service Part Only	

NOTE: Tire Chain Sets are not for use on All-Terrain Tires. Use only with tires listed at Item 10. Refer also to **BODY / CHASSIS ASSEMBLY (GHS MODELS)**, Page 4.

WIDE TAIL WHEEL / ALL-TERRAIN TIRE KIT & TIRE CHAIN SET

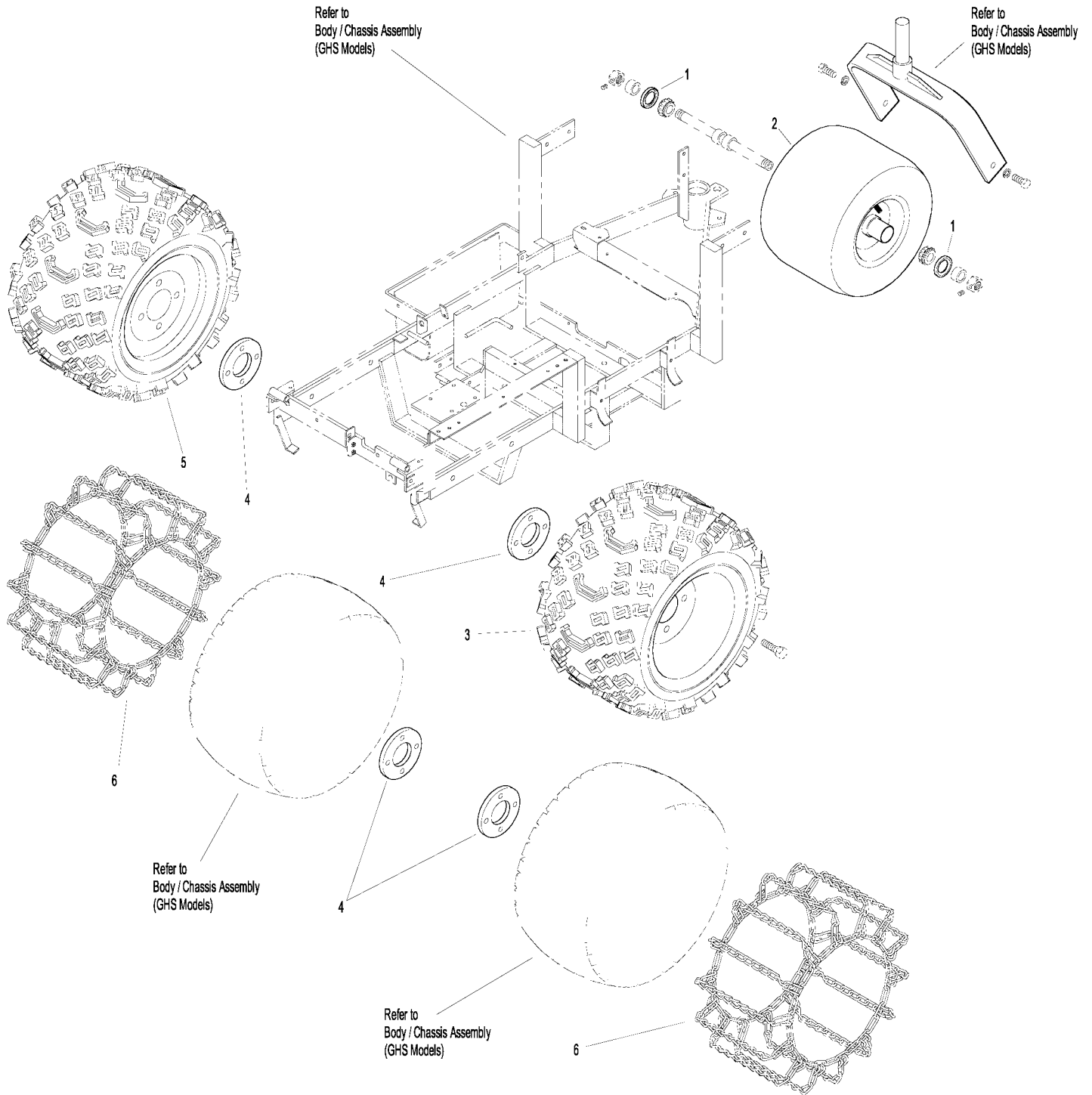

LUBRICATION POINTS

ITEM NO.	PART NO.	DESCRIPTION	NO. REQ'D	ITEM NO.	PART NO.	DESCRIPTION	NO. REQ'D
Lubrication Points				26		Belt Tightener Pivot, PTO Clutch	Grease 1
1		Deck Caster Wheel Fork Pivot	Grease 2	27		Brake Actuator Rod and Brake Band Pivot Pins (Clevis)	Oil 3
2		Deck Caster Wheel Bearing	Grease 2	28		Brake Actuator Pivot	Grease 1
3		Tee Gearbox, Deck	Oil* 1	29		Anti-Scruff Roller Wheel	Oil 2
4		Blade Drive Gearbox	Oil* 2	30		Catcher Hinge Point	Oil 2
5		PTO Shaft Guard Hinge	Oil 1	31		Rear Wheel Bearings	Grease 2
6		Universal Joint Shaft Assembly	Grease** 1	32		Engine Oil	Oil*** 1
7		Pivot Assembly, Tilt-Up Deck	Grease 4	33		Choke Control Cable Ends	Oil 2
8		Deck Support Arm Socket	Grease 2	34		Belt Tightener Pivot, Blower Drive (GHS Model Only)	Grease 1
9		Body Hinge Point	Oil 2	35		Belt Tightener Pivot, Ground Drive	Grease 1
10		FSC Actuator Rod Pivot Pins	Oil 2	36		PTO Gearbox Dipstick	Oil*** 1
11		FSC Lever Pivot	Grease 1	37		Hydrostatic Drive	Oil*** 2
12		FSC Lever Fork (Grease Slide Area)	Grease 1	38		Choke Control Pivot	Oil 1
13		(FSC) Friction Body Pivot	Grease 1	39		Throttle Control Pivot	Oil 1
14		Steering Lever Pivot	Grease 4	40		Discharge Chute Hinge	Oil 1
15		Deck Roller Wheel	Oil 2	41		Tilt-Up Latch Assembly	Oil 1
16		Deck Support Arm Pivot	Grease 2	42		Steering Lever Support	Oil 1
17		Deck-to-PTO Coupling (Grease Slide Area)	Grease 1				
18		Universal Joint Tube Assembly	Grease** 1				
19		Universal Joint Quick Connect Spline (Grease Slide Area)	Grease 1				
20		Parking Brake Lever	Grease 1				
21		Gear Axle	Oil*** 2				
22		Belt Tightener Pivot, Jackshaft Drive	Grease 1				
23		Throttle Control Cable Ends	Oil 2				
24		Clutch Actuator Push Rod	Grease 2				
25		PTO Clutch Lever Pivot	Grease 1				

* Gearboxes are permanently lubricated and sealed requiring no scheduled lubrication. Oil level should be checked only when an oil leak is noted. Refer to **Mower Deck Gearbox Lubrication** in this section.

** Grease every eight (8) hours.

*** Refer to MT **Owner's Manual** for procedure for checking and changing oil in Engine Crankcase, Hydrostatic Transmissions and Gear Axles.

NOTE: DGHS42 Tilt-Up Deck is shown for reference. For other Deck Lubrication Points, Refer to Deck and Carrier Frame **Illustrated Parts Manual**.

LUBRICATION POINTS

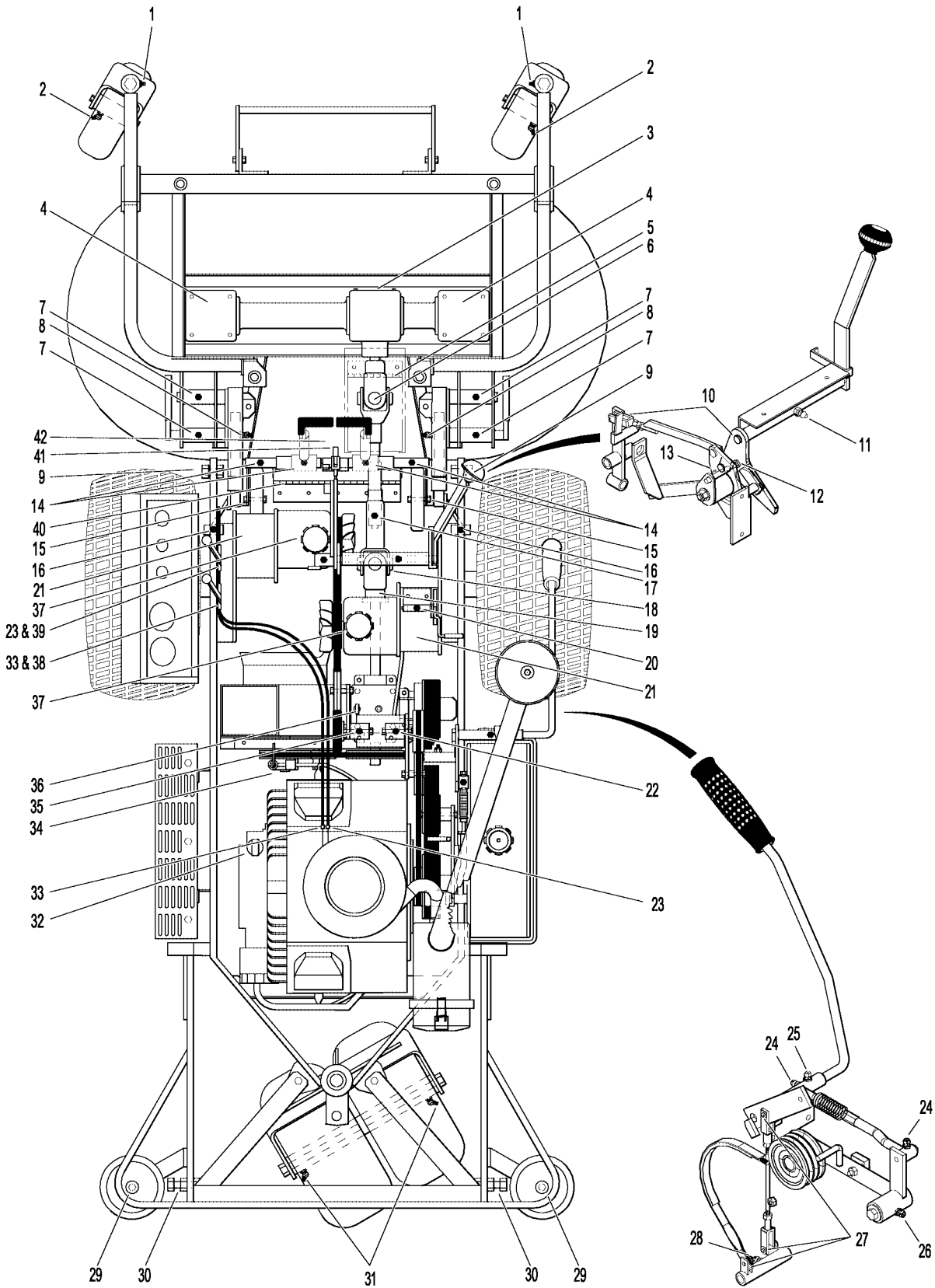

Effective Date 3/29/00

Use only genuine Walker® replacement parts.

EFI WIRING SCHEMATIC

OFF	G + M
START	B + A / S1 + S2
RUN	B + A

S1 = START CIRCUIT
 S2 = START / ACCESSORY CIRCUIT
 M = MAGNETO GROUND CIRCUIT
 B = BATTERY CIRCUIT
 A = ACCESSORY CIRCUIT
 G = GROUND CIRCUIT

J1 = #1 FUEL INJECTOR
 J2 = #2 FUEL INJECTOR
 J5 = THROTTLE POSITION SENSOR
 J7 = OIL TEMP SENSOR
 J9 = OXYGEN SENSOR
 J12 = ENGINE GROUND
 J15 = #1 IGNITION COIL
 J16 = #2 IGNITION COIL
 J17 = #1 IGNITION COIL
 J18 = #2 IGNITION COIL
 J19 = IGNITION COIL GROUND

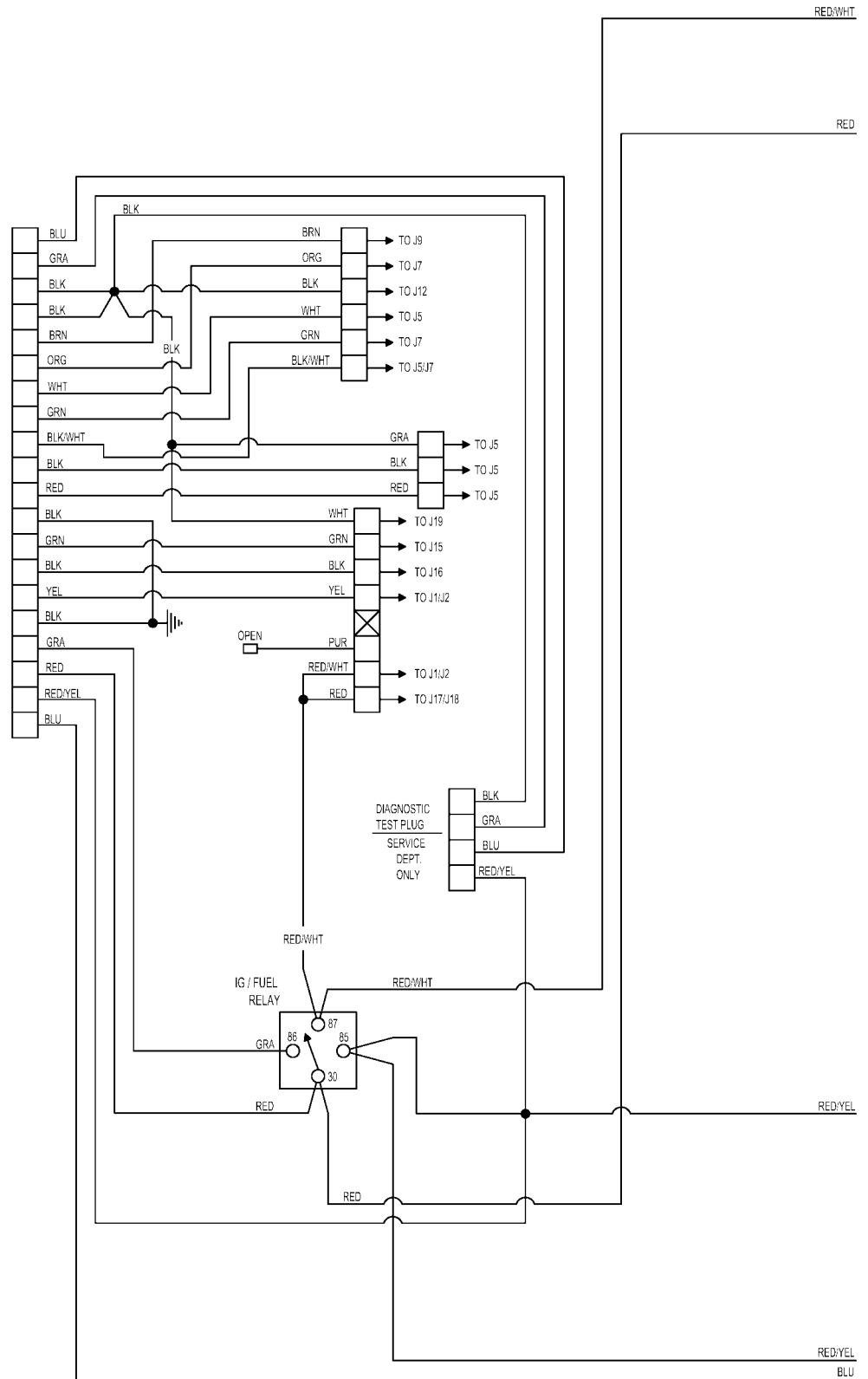

EFI WIRING SCHEMATIC

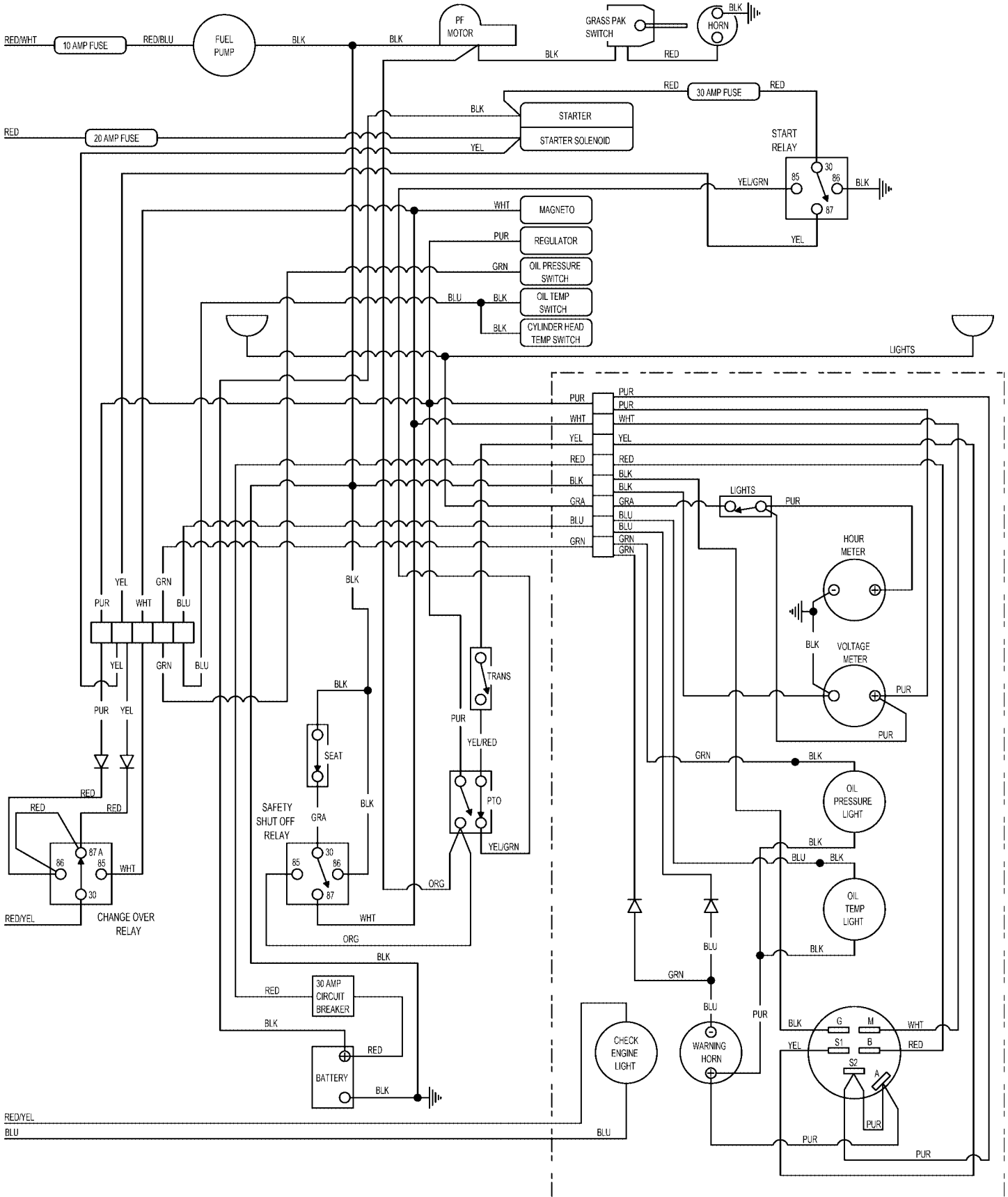

LIMITED WARRANTY FOR WALKER COMMERCIAL RIDER MOWER

1. WHAT THIS WARRANTY COVERS, AND FOR HOW LONG:

Walker Manufacturing company will, at its option, repair or replace, without charge, any part covered by this warranty which is found to be defective in material and/or workmanship within one (1) year* after date of sale to the original retail purchaser unless the product is used for rental purposes, in which case this warranty is limited to ninety (90) days. At Walker's request, customer will make the defective part available for inspection by Walker and/or return the defective part to Walker, transportation charges prepaid. All parts and components of the Walker Mower are covered by this warranty **except** the following components which are warranted separately by their respective manufacturers:

Kohler Engine
Kubota Engine
Kawasaki Engine
Eaton Hydraulic Transmission
Peerless Gearboxes
Battery
Tires

The available warranties covering these items are furnished with each mower. Walker does not assume any warranty obligation, liability or modification for these items, which are covered exclusively by the stated warranty of the respective manufacturers noted above.

* An extended three (3) year warranty is offered on the Walker P/N 6200-5 Gear Axle Assembly.

2. WHAT THIS WARRANTY DOES NOT COVER:

- A. This warranty does not cover defects caused by depreciation or damage caused by normal wear, accidents, improper maintenance, improper use or abuse of the product, alterations, or failure to follow the instructions contained in the Owner's Manual for operation and maintenance.
- B. The customer shall pay any charges for making service calls and/or for transporting the mower to and from the place where the inspection and/or warranty work is performed.

3. HOW TO OBTAIN SERVICE UNDER THIS WARRANTY:

Warranty service can be arranged by contacting the dealer where you purchased the mower or by contacting Walker Manufacturing Company, 5925 East Harmony Road, Ft. Collins, CO 80528. Proof of the date of purchase may be required to verify warranty coverage.

4. WARRANTY LIMITATION:

- A. **THERE IS NO OTHER EXPRESS WARRANTY. ANY WARRANTY THAT MAY BE IMPLIED FROM THIS PURCHASE INCLUDING MERCHANTABILITY AND FITNESS FOR A PARTICULAR PURPOSE IS HEREBY LIMITED TO THE DURATION OF THIS WARRANTY AND TO THE EXTENT PERMITTED BY LAW ANY AND ALL IMPLIED WARRANTIES ARE EXCLUDED.** Some states do not allow limitations on how long an implied warranty lasts, so the above limitations may not apply to you.
- B. **WALKER WILL NOT BE LIABLE FOR ANY INCIDENTAL, CONSEQUENTIAL, OR SPECIAL DAMAGES AND/OR EXPENSES IN CONNECTION WITH THE PURCHASE OR USE OF THE MOWER.** Some states do not allow the exclusion or limitation of incidental or consequential damages, so the above limitation(s) or exclusion(s) may not apply to you.
- C. Only the warranty expressed in this limited warranty shall apply and no dealer, distributor, or individual is authorized to amend, modify, or extend this warranty in any way. Accordingly, additional statements such as dealer advertising or presentations, whether oral or written, do not constitute warranties by Walker, and should not be relied upon.
- D. This warranty gives you specific legal rights, and you may also have other rights which vary from state to state.

WALKER MOWERS™

WALKER MFG. CO. • 5925 E. HARMONY ROAD, FORT COLLINS, CO 80528 • (970) 221-5614
FORM NO. 042600 PRINTED IN USA ©2000 WALKER MFG. CO
www.walkermowers.com